



Pellet boiler pellet^{top}

Operation manual for the system operator

Read carefully before operating.

DR-6011-EN / v29-201904

Content

1 About this manual	2	12.3 Register on the web server	27
2 Safety information	3	12.4 Install app, register user	28
3 Warranty, guarantee, liability	3	12.5 Add system	28
4 Product information	5	12.6 Use of the mySOLARFOCUS app	29
4.1 Proper use	5	12.7 Approve additional users	29
4.2 Fuel	5	13 Weatherman function	30
4.3 Product description	5	13.1 Information	30
4.4 Spare parts	5	13.2 Heating circuit	30
4.5 Type plate	5	13.3 Domestic hot water	31
4.6 CE declaration of conformity	5	13.4 Buffer tank loading	32
4.7 Safety devices	6	14 Maintenance (and cleaning)	32
4.8 Functional components	7	14.1 Required activities - overview	33
4.9 Combustion principle	8	14.1.1 Empty ash container	33
4.10 Efficient and low-emission operation	8	14.1.2 Boiler cleaning - manual activities	34
4.11 Technical specifications	9	14.1.3 Replace combustion grate	34
4.12 Dimensions	10	14.1.4 Check system pressure	35
5 Use and operation	11	14.1.5 Clean exhaust gas duct	35
5.1 Main screen of the control unit	11	14.1.6 Check safety valve	35
5.2 Boiler operating mode	11	14.1.7 Replace pellet suction turbine	35
5.3 Selection menu	11	14.1.8 Maintenance by qualified personnel	35
5.3.1 Heating circuit output test	12	15 Perform emissions measurement	36
5.4 Customer menu	12	15.1 Emission measurement for external boilers	36
5.4.1 Required boiler values	12	16 Filling the pellet store	36
5.4.2 Vacuum output	13	17 Troubleshooting	37
5.4.3 User lock	14	18 Boiler maintenance agreement	41
5.4.4 Message log	14	19 ErP product data sheet	43
5.4.5 Operating hours counter	14		
5.4.6 Qualified personnel menu	15		
6 Heating circuit	18		
6.1 Heating circuit settings	18		
6.1.1 Heating circuit operating mode	18		
6.1.2 General settings	19		
6.1.3 Heating curve	19		
7 DHW heating	21		
7.1 Domestic hot water tank	21		
7.1.1 DHW tank settings	22		
7.2 Fresh water module - FWM (optional)	22		
8 Recirculation control	23		
8.1 Circulation settings	23		
8.2 Recirculation control - Options	24		
9 Buffer tank	25		
10 Solar system	26		
11 Temperature difference charge control	26		
12 mySOLARFOCUS app	27		
12.1 Requirements for use	27		
12.2 Connecting the control to the internet	27		

1 About this manual

Dear customer,

To ensure reliable and efficient operation of your boiler, the following points are extremely important:

- Professional planning and installation of the heating system.
- Training of customers in starting up the heating boiler.
- Regular maintenance by the operator.
- Regular maintenance by qualified personnel.
- Comply with the specifications and instructions in this manual.

Software version for control unit

The guide describes the software version 19.040 of the *controleco*^{manager-touch}; *Main screen of the control unit* > 11

Language

The language of the original manual is German. All other language versions of this manual are translations of the original.

Storage

Keep the manual for the entire service life of the product and ready to hand. The manual must be passed on to the new owner when the product is dismantled/reused. If the manual is lost or destroyed, request a new copy from the manufacturer.

Tips and Warnings

The tips used in this manual are highlighted with symbols and signal words. The signal word indicates the level and nature of the danger and how to avert it.



Indicates information for correct handling of the product.



CAUTION - Failure to comply with this instruction could result in damage to property.



DANGER - Failure to comply with this instruction poses a danger to people.

Manufacturer

SOLARFOCUS GmbH
Werkstrasse 1, A-4451 St. Ulrich
Company register no. 281755x
Tel.: +43 7252 50 002-0, Fax: +43 7252 50 002-10
office@solarfocus.com
www.solarfocus.com

Technical questions about our products

- Service-Hotline
0043 7252 50002-4920
service@solarfocus.at

2 Safety information

Qualification of personnel

- The work procedures described in this manual must be carried out by qualified specialist personnel.
- Work on electrical components must be performed by trained electricians and in accordance with the relevant laws and directives.

Installation and commissioning

- System may only be serviced and put into operation by certified qualified personnel (SOLARFOCUS service technician or SOLARFOCUS service partner).

Keep unauthorized persons and children away

- Danger of burns due to hot lines and hot components, risk of injury from mechanically moving parts. Keep unauthorised persons away, do not leave children unattended, and control access to the boiler room and fuel storage room.

Safety devices

- Never disengage the safety equipment of the heating system. In case of failure, arrange for immediate repair.

Maintenance and repair

- Perform maintenance activities at the specified intervals. No or incorrect maintenance leads to inefficient operation, higher failure risk of the boiler and increased potential for hazards.
Recommendation: Conclude maintenance contract > 41
- Have repairs done by qualified personnel only
Improper repairs can lead to risks for the user and impaired operation
- Store hot ashes only in metal containers. Never put hot or warm ash in the dustbin. There is a great danger of fire.
- For repairs use only original spare parts or parts approved by the manufacturer (e.g. standard parts).

Damage to the system

- If the electrical insulation on cables, plugs, switches becomes damaged, switch off the voltage supply and have the insulation repaired.
- In the case of visible damage (e.g. thermal deformation, mechanical damage) the operation of the system must not be continued. The system may only be operated if it is in perfect technical condition.

3 Warranty, guarantee, liability

For warranty and warranty claims (with conclusion of a maintenance contract) observe the following points.

- The warranty begins at the time of handover (delivery note, commissioning form).
- The warranty period is calculated from the date of initial commissioning.

- The warranty periods are based on the relevant regulations.
- We must be notified promptly and accurately of any damage incurred, so that the cause can be clarified.
- The supply air into the boiler must not contain any aggressive substances (such as chlorine or fluorine compounds, used in cleaning agents, solvents, adhesives, etc.). These can cause corrosion in boiler and fireplace.
- If the system has defects despite correct installation (in compliance with the technical documentation), we grant a warranty provided that the system has been examined by the plant customer service (commissioning form).
- The guarantee applies to technical, construction-related faults and faults in the manufacture of the system that prevent correct and problem-free usage.
- We shall not be liable for components that we have not manufactured; however, we will be prepared to transfer our rights to claim against the manufacturer of defective components to the purchaser.
- In fulfilling the warranty/guarantee services, we shall cover only the assembly time and the materials used, but not any travel or accommodation costs necessary for the fitters/engineers or any return transport costs.
- SOLARFOCUS GmbH assumes no liability for any consequential costs of damages.
- The repair and/or warranty replacement shall be carried out on site or in the SOLARFOCUS factory at our discretion.
- The company SOLARFOCUS will determine whether such work requires a repair or whether the parts are to be replaced free of charge.
- No claims can be accepted under the warranty if unauthorised intervention (or action that has not been explicitly approved by us) has been carried out. In addition, the goods must be paid for within the specified payment timeframe.
- It is almost impossible to produce flawless painted parts; for this reason, slight defects that do not adversely affect proper use shall not be deemed as grounds for complaint.

Limitation of liability

SOLARFOCUS GmbH assumes no liability for injury or material damage resulting from:

- Failure to observe the instructions in this manual.
- Use of the product for any purpose other than for its intended use > 5.
- Deployment of unqualified personnel.
- Use of non-approved spare parts.
- Technical modification of the product by the system operator.

Expiry of maintenance, warranty and guarantee services:

The maintenance, warranty and guarantee services expire if one of the following points applies:

- Non-observance of information in the planning, installation and operation manual.
- Faults that occur due to use of unsuitable fuels > 5.
- Commissioning and maintenance carried out by non-certified companies.
- Undocumented commissioning and maintenance checklist
- Incorrect operation and failure to perform maintenance and cleaning as prescribed.
- Damage due to force majeure (water, fire, etc.).
- Damage during transport.
- Wilful damage.
- Insufficient energy or water, fault in the hydraulics.
- No functioning return booster module installed.

4 Product information

4.1 Proper use

- The heating boiler **pellet^{top}** is intended for heating up water in closed heating systems.
- Only use fuel as specified in the next chapter *Fuel*.

4.2 Fuel

Pellets

Use wood pellets only in accordance with these specifications:

- Pellets according to the ISO 17225-2 standard, class A1.
- Pellets that meet the additional ENplus certification.
- Pellets that meet the additional DINplus certification.



4.3 Product description



- The **pellet^{top}** is a boiler for the combustion (gasifier technology) of wood pellets
- The boiler has an automatic fuel ignition system, automatic fuel supply and automatic cleaning of the heat exchanger.
- The ash produced is collected in an ash box, which must be emptied at regular intervals.

4.4 Spare parts

For repairs use only original spare parts or parts approved by the manufacturer (e.g. standard parts).

The manufacturer cannot accept any liability for damage caused by spare parts not authorised by the manufacturer.

4.5 Type plate

pellet^{top} Kesseltype	9999-01106F52 Seriennummer	
10,4 - 35 kW Leistung	58 Liter Wasserinhalt	max. 3 bar Betriebsdruck
max. 80°C Vorlauftemperatur	230 V~/50 Hz 10 A	Saug: 2100 W <small>El. Anschlussleistung ohne Pumpen</small>
Pellets Brennstoff	Norm EN14961-2 d= 6mm	IP 20 Kesselklasse: 5
Art.-Nr.: 67145	Gepr.:	

SOLARFOCUS GmbH
A-4451 St. Ulrich/Steyr
Werkstrasse 1

SOLARFOCUS
macht unabhängig



Service Tel.: 0043 (0)7252 50002 4920

in DE: 0180 500 92 10

4.6 CE declaration of conformity



The conformity of the produce is declared by the manufacturer in accordance with the Machinery Directive 2006/42/EC; the documents are available for inspection at the manufacturer.

The product corresponds to Directive 2011/65/EU (RoHS 2) and does not use any materials containing asbestos. The product does not contain any PCB or mercury.



product	certification number
pellet ^{top} 15	HTSMCS0911/01
pellet ^{top} 25	HTSMCS0911/02
pellet ^{top} 35	HTSMCS1212/01
pellet ^{top} 45	HTSMCS1408/01

4.7 Safety devices

Heat dissipation

- This function of the boiler control is a safety device that prevents overheating of the boiler.
- Functioning: If the boiler temperature exceeds the set *Heat dissipation maximum boiler temperature* (in the service menu - *General Settings*), all pumps relating to the energy consumer units (e.g. heating circuit, DHW tank, buffer tank, etc.) will be switched on and the heating circuit mixer opened. In this way, energy is drained from the boiler and it may be possible to prevent other safety devices tripping.
- If the boiler temperature falls below the set *Heat dissipation maximum boiler temperature* minus 1°C again, the pumps and mixers will be operated in standard mode again.

Overtemperature reset (OTR)

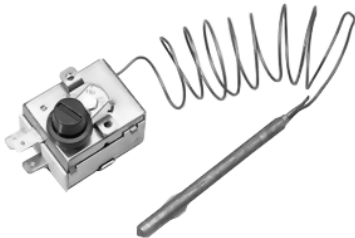

The safety temperature limiter (STL) is a safety device that prevents overheating of the boiler.

Functioning: The STL stops the heating process at a boiler temperature ~95°C (exclusively electrical function; fuel and air supply are interrupted).

After tripping, the STL must be manually released again by unscrewing the black sealing cap **1** and pressing the button as soon as the boiler temperature falls below 60°C.

If the safety overtemperature reset trips, this is indicated in the boiler control display.

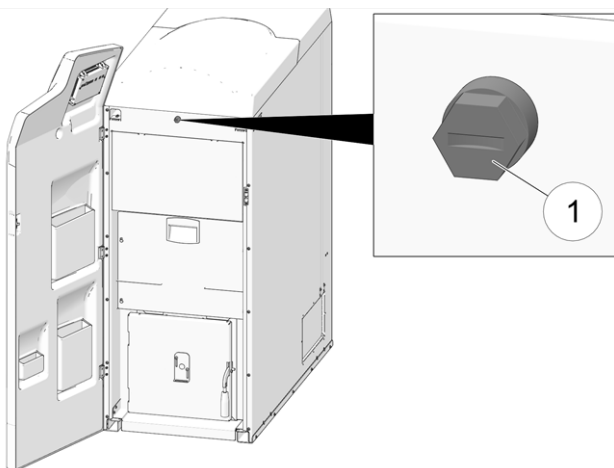

Fig. 2-1: Position of the overtemperature reset

Thermal overload protection



- The thermal overload protection prevents an uncontrolled increase in temperature and pressure inside the boiler.
- Functioning: At a boiler temperature > 95°C, the valve opens and directs cold water through the safety heat exchanger (which is placed in the water jacket of the boiler). This lowers the boiler temperature.

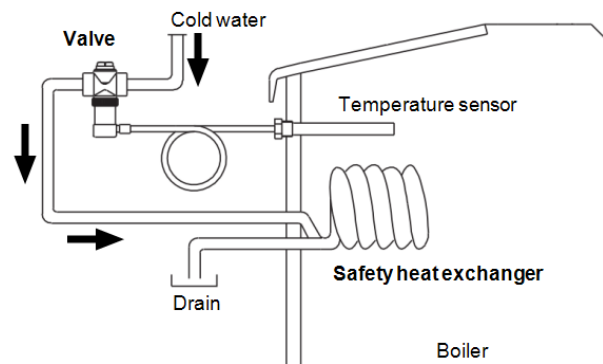

Fig. 2-2: Schematic diagram

Safety valve (to protect against excess pressure in the system)

- The safety valve **1** is a safety device for protecting against overpressure in the water circuit of the heating system.
- Functioning: The valve opens when the system pressure exceeds 3 bar. Water/steam are discharged into an open drain via a discharge line, which avoids consequential damage to the heating system. The valve is closed during normal operation.
- For normative specification see EN 12828.

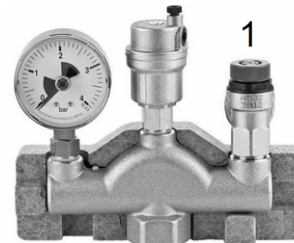

Fig. 2-3: Safety valve integrated into boiler safety group

EMERGENCY OFF switch



- The EMERGENCY OFF switch is a manually operated safety device. The burner and the fuel supply to the boiler are stopped. Circulation pumps remain in operation to dissipate heat and cool the boiler.
- The switch must be installed outside the boiler room in a safe place that is easy to access.

4.8 Functional components

pellet^{top} 35/45

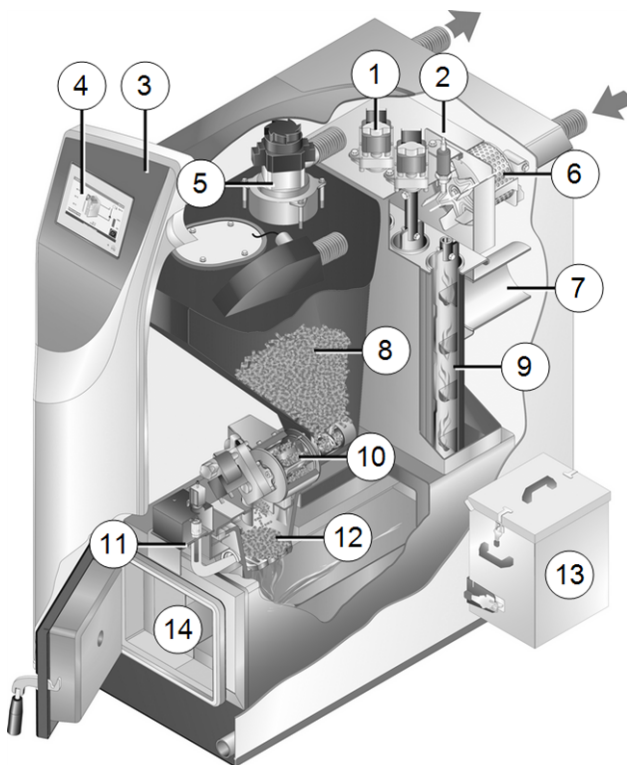

- 1 Motors for heat exchanger cleaning
- 2 Lambda sensor
- 3 Cladding door
- 4 Controls (touch display)
- 5 Suction turbine for conveying the pellets
- 6 Induced draft fan
- 7 Flue gas pipe
- 8 Intermediate pellet store
- 9 Heat exchanger cleaning
- 10 Screw pellet feeder and rotary valve
- 11 Ignition device (glow pencil)
- 12 Combustion grate
- 13 Ash container
- 14 Combustion chamber

pellet^{top} 49/70

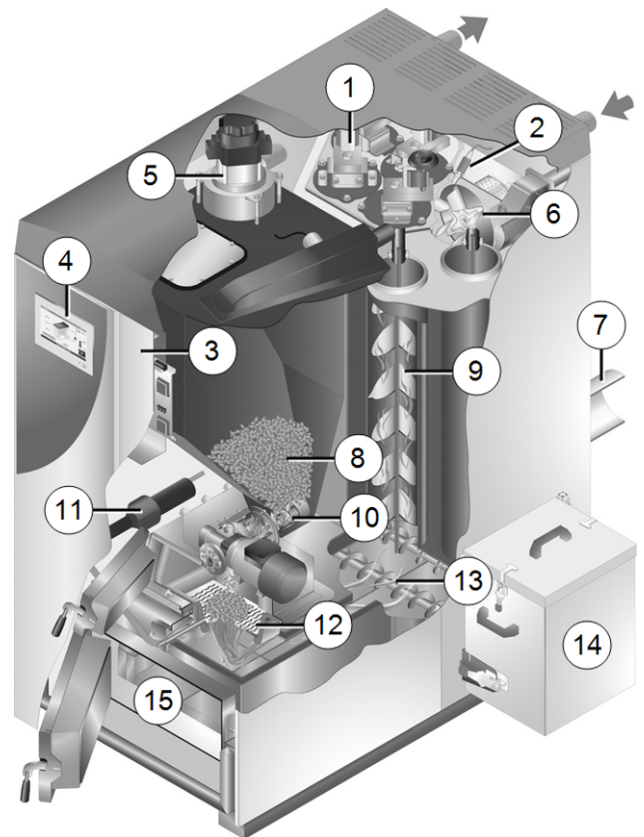

- 1 Motors for heat exchanger cleaning
- 2 Lambda sensor
- 3 Cladding door
- 4 Controls (touch display)
- 5 Suction turbine for conveying the pellets
- 6 Induced draft fan
- 7 Flue gas pipe
- 8 Intermediate pellet store
- 9 Heat exchanger cleaning
- 10 Screw pellet feeder and rotary valve
- 11 Ignition device (hot air fan)
- 12 Combustion grate
- 13 Autom. ash extraction (auger)
- 14 Ash container
- 15 Combustion chamber

4.9 Combustion principle

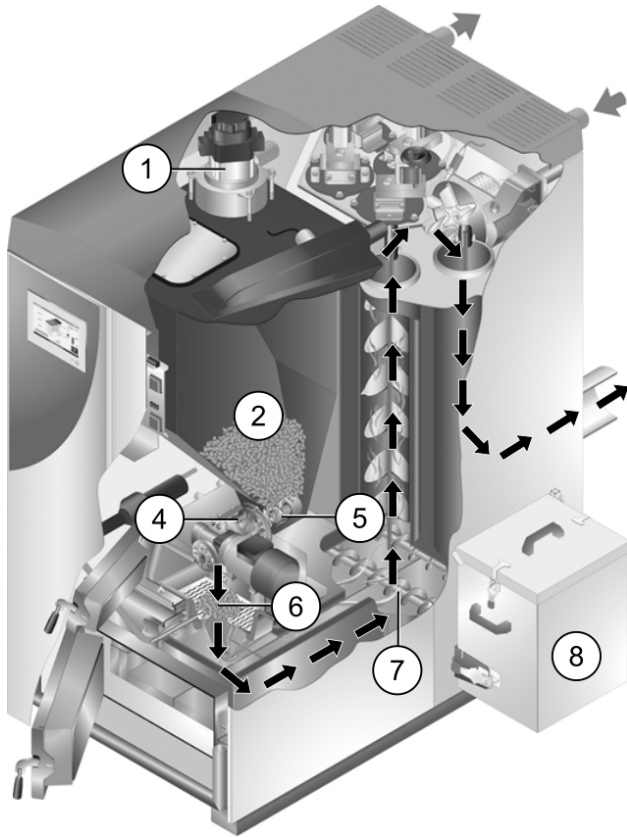

This tank stores the water heated by the boiler, allowing the connected devices (e.g. heating circuit, DHW tank, fresh water module, etc.) to access it as required. This ensures sufficiently long, uninterrupted combustion periods for the boiler.

Use of high-efficiency heating pumps

When using external heating pumps (e.g. return temperature rise, heating circuit pumps, etc.), high-efficiency pumps with energy efficiency class A should preferably be used.

This delivers savings potential of up to 80 % in drive energy (compared to conventional heating pumps) with identical feed results.

Fuel path

The pellets are sucked by the suction turbine **1** into the pellet storage tank **2**. The pellet auger **5** and rotary valve **4** transport the pellets to the filling chamber, where they fall onto the combustion grate **6**. The pellets are burned using the pellet dropping method. The ash produced during combustion is transported by the ash extraction auger **7** to the ash box **8**.

Airflow

The air required for combustion is sucked into the filling chamber through the primary air damper, downwards through the combustion grate into the combustion chamber, on through the heat exchanger, and leaves the boiler via the induced draught fan into the flue gas pipe.

4.10 Efficient and low-emission operation

Please note the following recommendations from the EU Energy Efficiency Directive:

Use of a buffer tank

As the most complete combustion of wood pellets is possible only when the boiler is in normal operation and as greater losses and higher emissions occur during the warm-up and burn-out phases, the use of a buffer tank is recommended.

4.11 Technical specifications

pellet^{top}		35	45	49	70
Rated power	[kW]	35	44.9	49	70
Lowest output	[kW]	10.5	13.4	14.7	21
Energy efficiency class		A+	A+	A+	A+

Dimensions

Width (W)	[cm]	55.5	55.5	79	79
Total width including ash box (B1)	[cm]	94	94	120	120
Total depth	[cm]	144	144	155	155
Depth without fan (D)	[cm]	134	134	145	145
Height incl. adjustable feet ^[1] (H)	[cm]	156	156	172	172
Minimum room height ^[2]	[cm]	175	175	195	195

Weight

Weight	[kg]	554	560	882	882
--------	------	-----	-----	-----	-----

Water side

Water content	[l]	58	58	130	130
Max. permissible operating pressure	[bar]	3	3	3	3
Connection Boiler inflow/Boiler return flow	["]	AG 5/4"	AG 5/4"	AG 6/4"	AG 6/4"
Drain	["]	AG 1/2"	AG 1/2"	AG 1/2"	AG 1/2"
Thermal overload protection	["]	AG 1/2"	AG 1/2"	AG 1/2"	AG 1/2"
Flow rate / differential pressure at ΔT 10°K	[kg/h]	3000	3860	4200	6000
	[hPA]	45	95	50.6	59
Flow rate / differential pressure at ΔT 20°K	[kg/h]	1500	1930	2100	3000
	[hPA]	11	17.5	13	16

Fuel

Fuel		Wood pellets acc. to EN17225-2, ENplus-A1			
Capacity of intermediate pellet store	[l]	95	95	250	250

Flue gas side

Flue gas pipe diameter	[cm]	15	15	20	20
Height centre of flue gas pipe ^[1] (D)	[cm]	46	46	59	59
Flue gas mass flow full load	[g/s]	30	37	40	55
Flue gas mass flow partial load	[g/s]	10	13.5	14	20
Maximum flue gas temperature ^[4] full load	[°C]	140	140	140	140
Maximum flue gas temperature ^[4] partial load	[°C]	100	100	100	100
Minimum draught requirement ^[5]	[Pa]	5	5	5	5

Emissions according to test report

Flue gas values ^[6] from test report: Test institute / test report no.	TÜV Austria11-UW-Wels-EX-212-2	TÜV Austria11-UWWels-EX-619	TÜV Austria11-UWWels-EX-212	TÜV Austria11-UW-Wels-EX-212-1	
CO full load	[mg/m ³]	10	9.1	8.8	7
CO Partial load	[mg/m ³]	48	42.6	40.4	29
NOx full load	[mg/m ³]	101	103	104	108
NOx partial load	[mg/m ³]	102	106.9	109	119
Org. C full load	[mg/m ³]	<2	<2	<2	<2
Org. C partial load	[mg/m ³]	<2	<2	<2	<2
Dust content full load	[mg/m ³]	20	20	20	20
Dust content partial load	[mg/m ³]	17	17.6	17.8	19

[1] Adjustable feet at maximum depth of thread

[2] The minimum room height is required for maintenance work

- [3] Intermediate store for manual filling
- [4] Flue gas temperature can be adjusted electronically.
- [5] A draught stabiliser must be fitted if the specified draught of 15 Pa is exceeded (Caution: In a boiler with room-sealed operation, use a room-sealed independent draught limiter)
- [6] Flue gas values in mg/m³ are based on 13% O₂ of the volume flow

4.12 Dimensions

pellet^{top} 35 / 45

(ash container may be mounted on the right or left.)

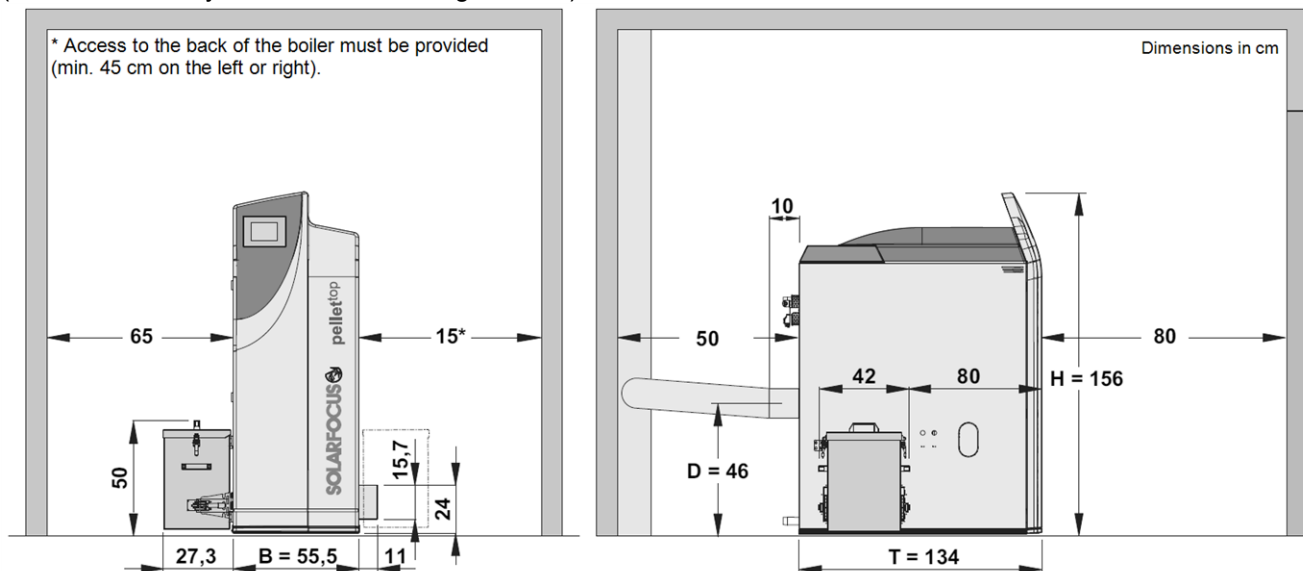

pellet^{top} 49 / 70

(ash container may be mounted on the right or left.)

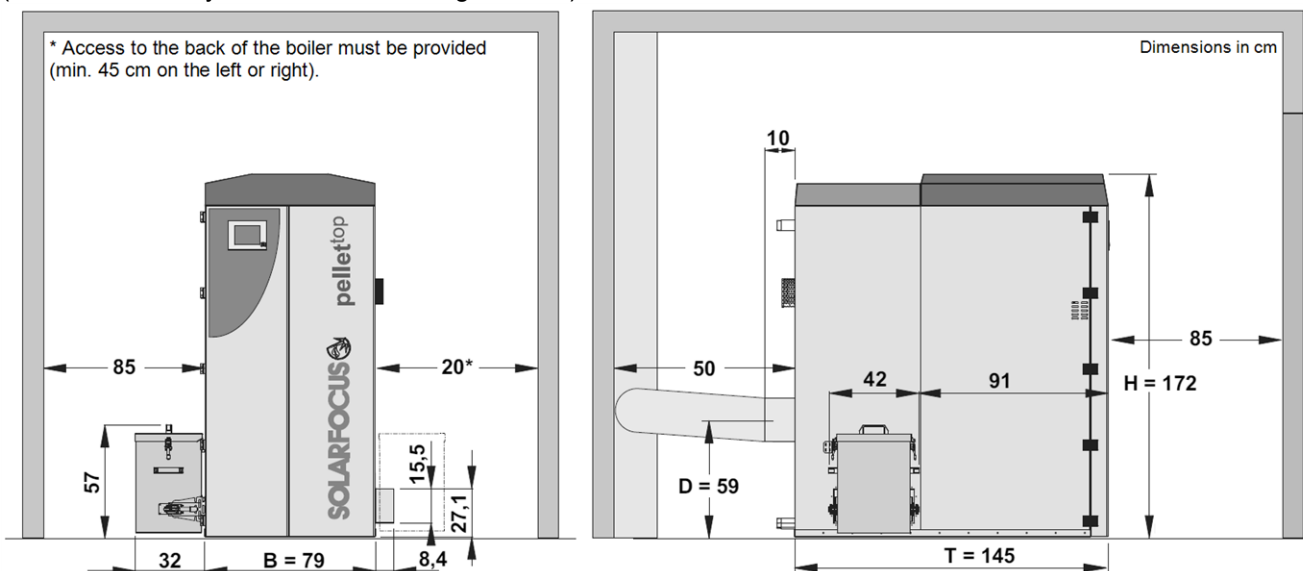

i Depending on the choice and arrangement of the transport system, additional space must be allowed for installation!

5 Use and operation

Touch display for operation

If the boiler is supplied with a mains power supply, the boiler control starts **seco** *manager-touch*. The control is started up to show the main screen.

 Operate the touch display with your fingers, do not use any hard objects.

If no inputs are made for 5 minutes (factory setting), the display will switch to standby mode.

Tapping the display again restarts the display with the main screen.

Buffer battery in operating element

A replaceable buffer batter (CR2032) ensures that data (time, settings) are retained in the operating element when the supply voltage is switched off.

5.1 Main screen of the control unit

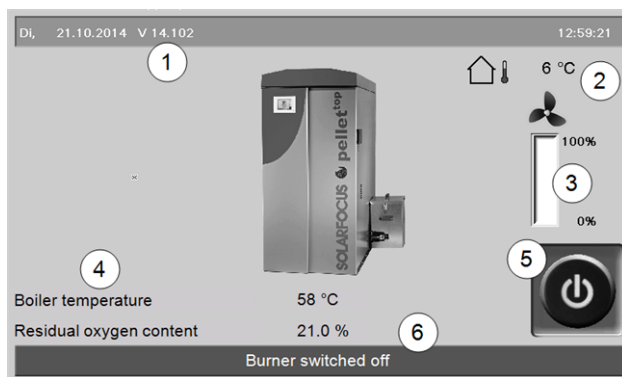
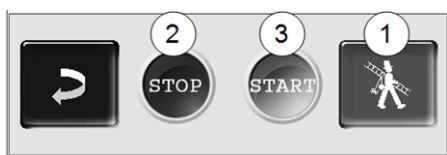

Fig. 2-4: Main screen

- 1 Software version for control unit
- 2 Outside temperature
- 3 Boiler output (rotational speed of induced draught fan)
- 4 Boiler temperature and residual oxygen content in flue gas
- 5 Boiler operating mode > 11
- 6 Status line

Tapping the main screen changes to the *Selection menu* > 11

5.2 Boiler operating mode



1 Chimney sweep function

This function is used to perform the emission measurements prescribed by law.

- Perform emissions measurement > 36

2 STOP

The burner is switched off. No heating requirements of the consumers are fulfilled.

! **WARNING** - The burner must not start! Only the automatic start-up of the heating circuit pump is active to protect against frost.

3 START

After pressing the *START* button, the burner is in the selected operating mode and ready for operation, and is able to fulfil heating requests from the consumers. The burner goes into standby as soon as a heating request is fulfilled, or the time release > 12 is no longer available.

5.3 Selection menu

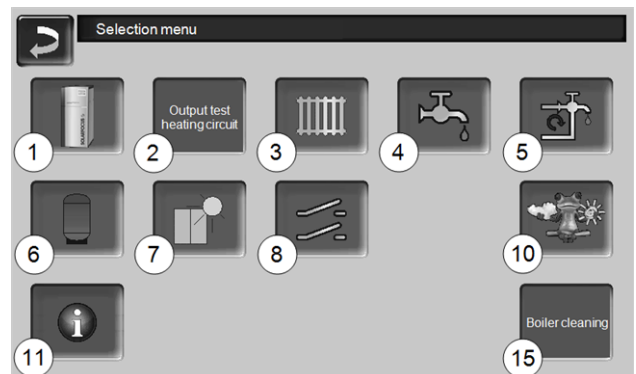

Fig. 2-5: Selection menu

- 1 Customer menu > 12
- 2 Heating circuit output test > 12
CAUTION, only to be undertaken by qualified personnel.
- 3 Heating circuit > 18
- 4 Domestic hot water heating > 21
- 5 Circulation control (optional) > 23
- 6 Buffer tank (optional) > 25
- 7 Solar system (optional) > 26
- 8 Temperature difference, charge control (optional) > 26
- 10 Weatherman function (optional) > 30
- 11 Information
- 15 Boiler cleaning > 32

5.3.1 Heating circuit output test

The available outputs can be switched on/off directly using the button. Can be used to test function of individual components.

! **CAUTION** - Only to be undertaken by qualified personnel.

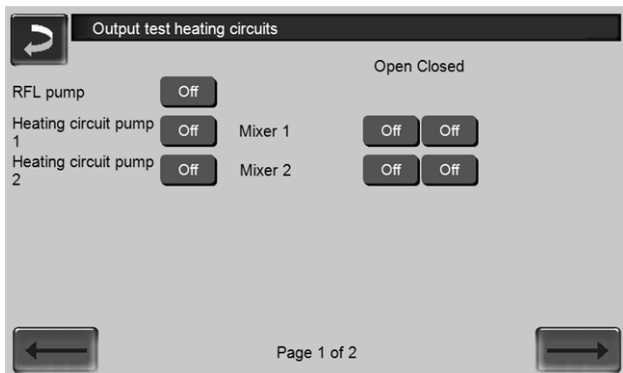

Fig. 2-6

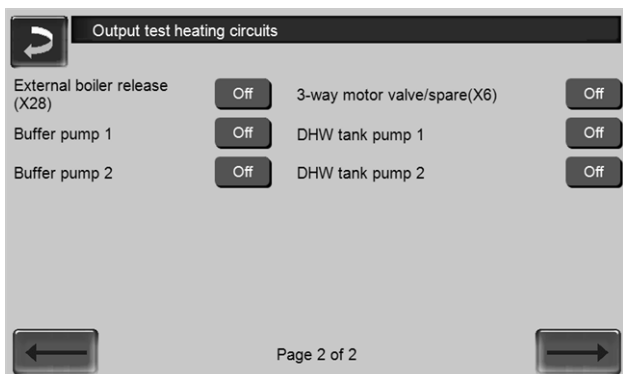

Fig. 2-7

5.4 Customer menu

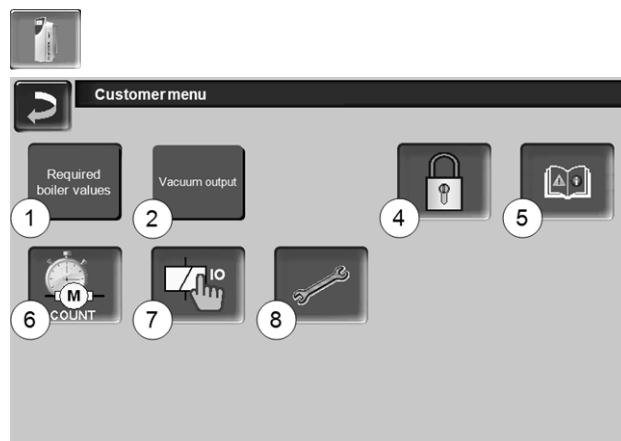

Fig. 2-8

- 1 Required boiler values > 12
- 2 Vacuum output > 13
- 4 User lock > 14
- 5 Message log ^[2] Record alarm and notifications > 14
- 6 Operating hours counter > 14
- 7 Output test boiler (CAUTION, only to be undertaken by qualified personnel).
- 8 Qualified personnel menu > 15

^[2] Button is only visible if a message is active.

5.4.1 Required boiler values

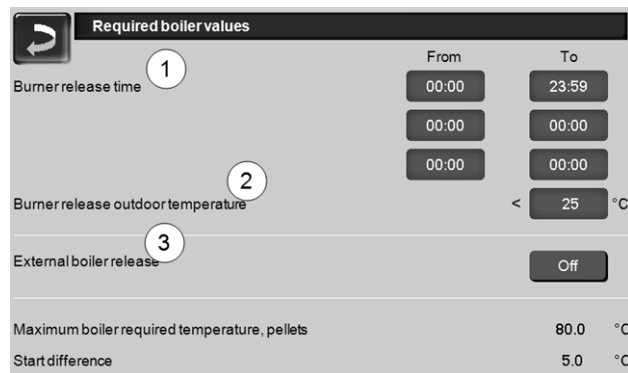

Fig. 2-9: Required boiler values

Burner release time 1

The burner can start within the release times; outside of these times, starting does not take place and/or the burner is stopped. A release time from 00:00 to 23:59 means that no restriction is pending and the burner can start at any time.

! **CAUTION** - In order to protect against frost, only automatic start-up of the heating circuit pump is active outside time release.



Domestic hot water heating in summer

If the boiler is used for heating domestic hot water, then the required chimney pull of 5 Pa may not be present in the summer months (or outside the heating period). This may result in smoke escaping in the boiler room.

Reason: High temperature on the chimney head (greater than 30°C); as a result the cooler air does not rise (~ 20°C air temperature when the burner starts) in the chimney.

Remedy: Set the burner time release from 00:00 to 07:00 or from 21:00 to 23:59.

Burner release outdoor temperature 2

The burner may not start if the outside temperature exceeds this value.

External boiler release 3

On switches the function to standby. I.e. a connected external boiler may only start when it receives the release from the SOLARFOCUS boiler (e.g. on the basis of a lack of fuel, operating fault).

5.4.2 Vacuum output

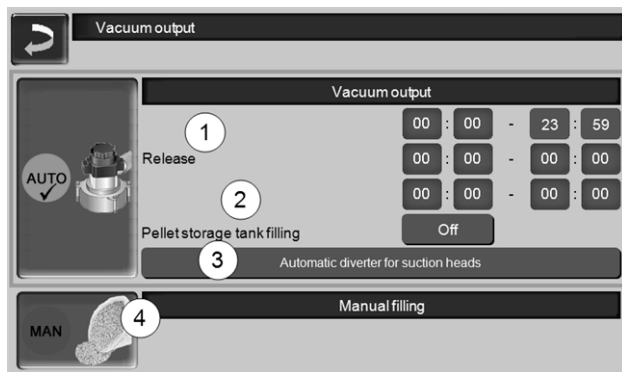

Fig. 2-10: Vacuum output

Release 1

Within the release times, the pellet suction turbine can start. A release time from 00:00 to 23:59 means that no restriction is pending and suction can start at any time.

Intermediate pellet store filling 2

Pressing the button starts the suction turbine and the tank is filled once (i.e. current level and release times are not considered). Prerequisite: the boiler must have the status *Switched off* or *Standby*.

Manual filling 4

Pressing the button deactivates the automatic suction extraction, i.e. the suction turbine cannot start. (e.g. for manual filling of the intermediate pellet store through the inspection flap 5).

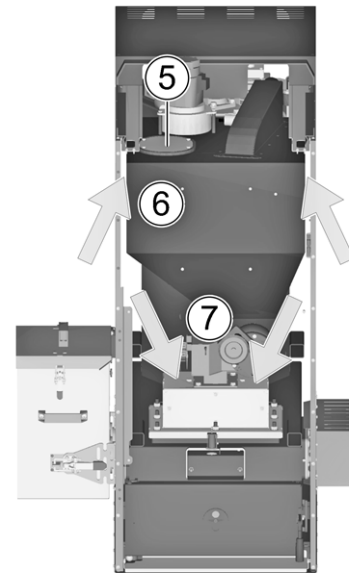

DANGER - Pellets falling down next to the container 6 may remain on the top side 7 of the pellet burner. Risk of uncontrolled ignition.

- ▶ Avoid pellets falling down, e.g. use a stainless steel hopper when filling.
- ▶ Remove pellets, which have fallen down, from the top side of the pellet burner (the cover on the front of the boiler must be removed in order to do this).

Automatic suction probe switch unit 3

Optional, i.e. the button of the same name and the screen are only visible when if this item has been obtained.

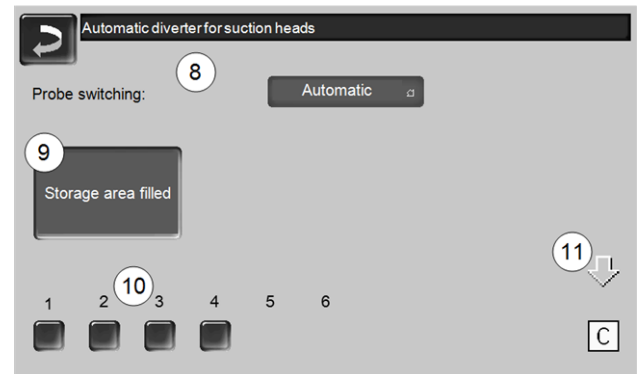

Fig. 2-11

Probe switching 8

Automatic (recommended setting): After three successful suction procedures at a probe, the system switches to the next probe. An even reduction of the level in the pellet storage area is achieved.

Selectively: the probes are successively sucked empty.

Only probe: suction is performed without exception at the preset probe. Switching to the next head must be performed manually at the control.

Storage area filled 9

- Pressing the button marks all suction probes 10 again as full (e.g. after filling the storage room). Pressing the Status button changes the probe status (colour red: Head is empty; colour green: Head is full).
- Red marking means: Probe is suctioned empty.
- Green marking means: Probe is full.
- The arrow 11 above the heads shows the currently used head. Position C means that the pellet hose has been suctioned empty (happens automatically, lasts a few seconds).

5.4.3 User lock

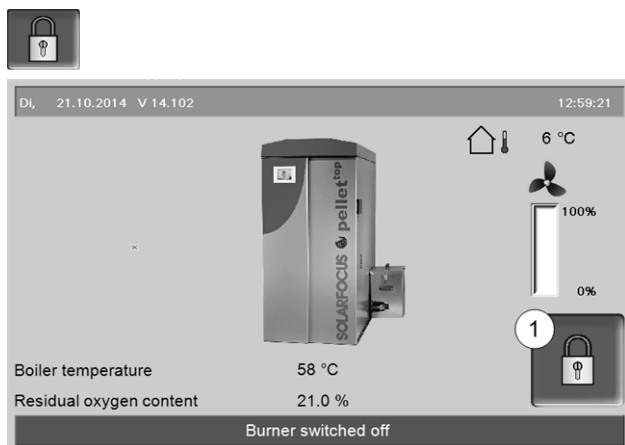

Fig. 2-12

The function serves as protection against unauthorised modification of the control parameters. When the user lock is active, the parameters of the individual screens are displayed but cannot be changed. The active user lock is indicated by the padlock icon 1 in the screens.

User lock screen

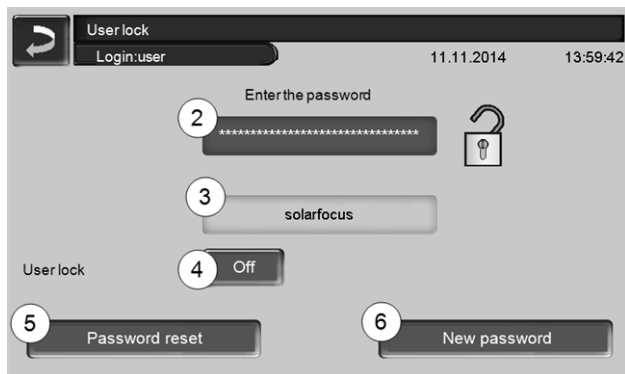

Fig. 2-13

Enter the password 2

To define a new password (maximum 20 characters).

Password 3

The currently valid password is displayed.

User lock 4

Off: The user lock is switched off.

On: Switches on the user lock function. If the display is not touched for one minute, the user lock is active in the screens.

Password reset 5

The current password is reset to the value *solarfocus*.

Accept as new password 6

Enter a new password in the input field and press the button. Note on screen keyboard; Confirm input with the  button.

5.4.4 Message log



Fig. 2-14

Every fault message which has occurred in the control unit is recorded here, with the time that it began and ended. The message with the highest priority is highlighted in red, acknowledged messages are highlighted in green.

Press the 2 button to quit messages. Button 1 opens the power failure log.

Possible messages > 37

5.4.5 Operating hours counter

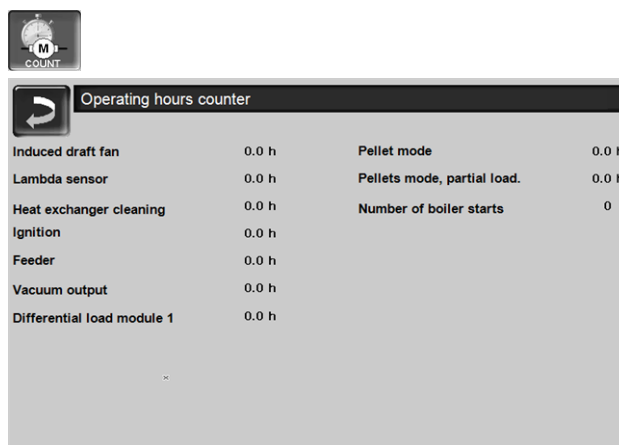

Fig. 2-15

5.4.6 Qualified personnel menu

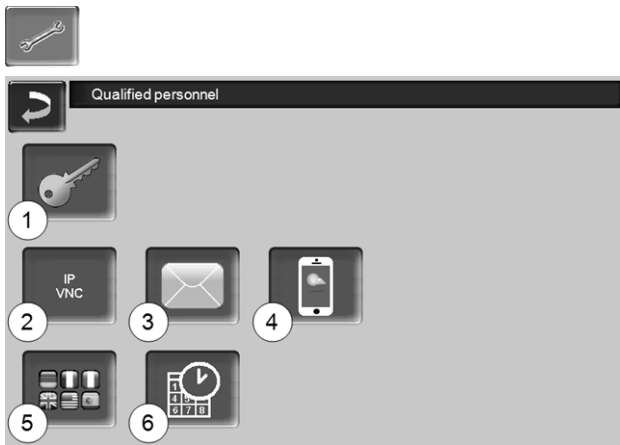

Fig. 2-16

- 1 Service menu > 15
- 2 IP VNC (for remote access) > 15
- 3 Sending emails > 16
- 4 mySOLARFOCUS-App > 27
- 5 Language selection > 17
- 6 Date and time > 17

5.4.6.1 Service menu



In the *Service menu* there are technical (factory pre-defined) settings for an optimum combustion process in the boiler. These can only be accessed by qualified personnel (code input required).

5.4.6.2 IP VNC (for remote access)

The control unit *eco^{manager-touch}* allows access to the control unit screens from a PC or mobile device (e.g. smartphone). This is effected via VNC (Virtual Network Computing) software. The control has an integrated VNC server, while the *VNC Viewer*, which is available free of charge on the Internet, is required for remote access.

A cable connection is required on site for the connection of the control unit to the router. Use the Ethernet socket (type RJ45) on the rear of the control panel (Touch display).

- i** Installation and configuration of this function must be performed by the customer (i.e. not included in the commissioning, service and support activities).

The following points are helpful for setting up a PC/-router to control the VNC server, which requires knowledge of networking technology.

IP configuration



- ▶ To access the *IP-VNC* icon, select it in the control
 - *Selection menu* screen
 - *Customer menu* screen
 - Trained qualified personnel button 
- ▶ Enter the data for your router. Recommend process:
 - Select *DHCP ON*.
 - The IP address is determined.
 - Select the *DHCP OFF + Apply button*.

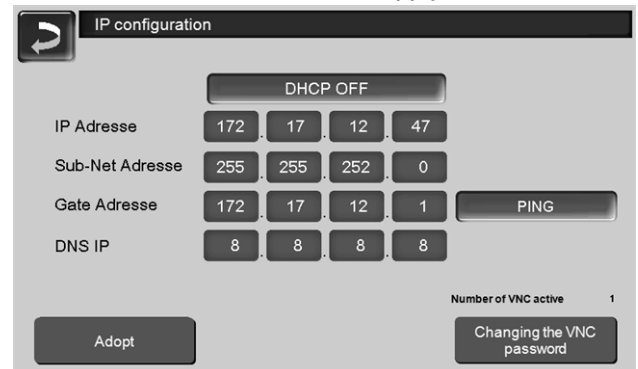
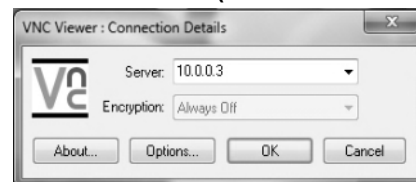

Fig. 2-17

- The IP address must be unique in each Ethernet network and is dependent on the other network components (PC, modem/router, etc.).
- Recommendation: Set a fixed IP address (= *DHCP OFF*), i.e. the control unit has a constant IP address.

Version 1: Installation of VNC viewer for access from a local PC (PC in the home network)



- ▶ Download the free VNC Viewer from the Internet, install it on the PC and start the application.
- ▶ Enter the previously defined IP address of the control.
 - As soon as the VNC Viewer is able to access the control unit, a password must be entered.
 - The password predefined by the manufacturer is *solarfocus*
 - After login, the screen view of the control unit is available.

Changing the VNC password



Fig. 2-18

- ▶ Press the *Change VNC password* button on the *IP setup view*.
- ▶ To change it, first enter the old password, then the new password, then press the *Accept* button.
- ▶ The new password must be used to log on after restarting the VNC Viewer on the local PC.
- ▶ Press the *Reset password* button to reset the password to the default password *solarfocus*.

Version 2: Installation of VNC viewer for access from an external PC (PC outside the home network)

- The user's local router does not always have the same IP address on the Internet (it is allocated by an *Internet Service Provider – ISP*).
- Nevertheless, Dynamic Domain Name Systems, also referred to as *DynDNS* or *DDNS*, allows access to the router.
- These systems allow a unique host name to be assigned on the Internet; the unique name is then also entered in the router. If the router is then assigned a different address by the ISP, it enters the updated IP address as the defined host name on the DynDNS server. The router and therefore the home network can then be reached using this host name.
- To create a connection with the control unit, a **port diversion** is required from the external port of the router^[1] to the IP address and to VNC port 5900 of the control unit.

[1] Port 5950 is recommended

i **Avoid any port forwarding** from external port 5900 of the router to IP address and VNC port 5900 of the control.

5.4.6.3 Sending e-mails



Function: The boiler control **eco**manager-touch automatically sends status e-mails and alarm e-mails (to stored addresses) if required.

Status e-Mail: An automatic e-mail (e.g. sent daily) provides information on the current boiler status.

Alarm email: a message is sent when a fault occurs.

i Installation and configuration of this function must be performed by the customer (i.e. not included in the commissioning, service and support activities).

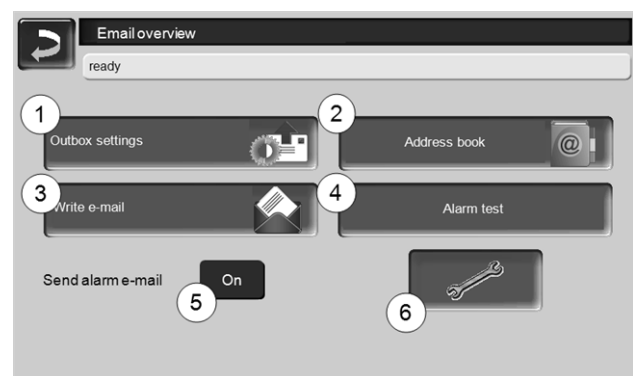

Fig. 2-19

Outgoing mail server 1

Enter the access data for the e-mail server you use.

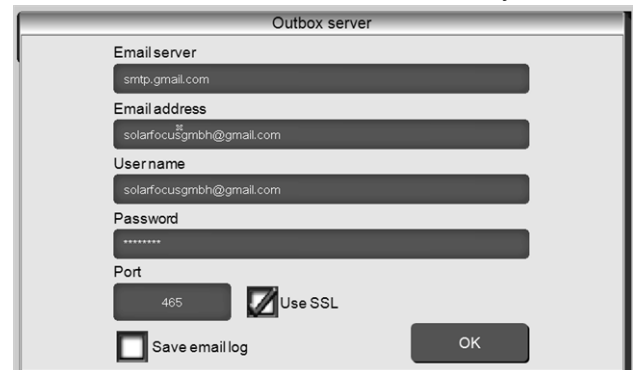

Fig. 2-20

Use SSL: Select if the e-mail server uses a TLS/SSL encryption protocol.

Address book 2

A maximum of 10 contacts can be added. If there are several addresses for a contact, these should be comma-separated.

Write e-mail 3

Used to manually send e-mails. The recipient's address can be selected from the address book using **To** and **CC** or manually entered in the recipient line.

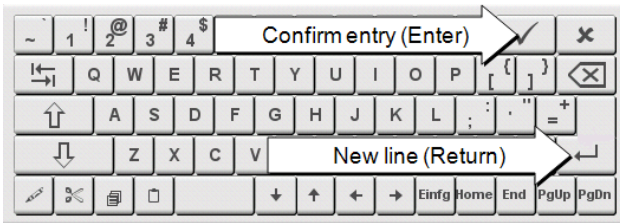

Alarm test 4

Used to test the e-mail settings. Pressing the button sends an e-mail to the *Recipient status email*.

Send alarm email 5

Activates/deactivates the automatic sending of alarm e-mails. The sending of status e-mails is not affected by this.

Alarm configuration 6

Settings for the alarm e-mails to be sent automatically.



Fig. 2-21

Alarm subject: is used for all alarm e-mails and status e-mails, therefore it should be as meaningful as possible (e.g. boiler type / name of system operator; 40 characters available).

Alarm groups: For prioritisation of the alarm messages (e.g. Alarm group 1 receives all messages, Alarm group 2 receives only safety-related messages, such as information on faults).

Status e-Mail: Set time at which the status e-mail is sent. The automatically generated content of the status e-mail is:

- Current status of the heating system
- Fault present, and which

Alarm selection: This is where you define which alarm group is reported for which event.

5.4.6.4 mySOLARFOCUS app



Pressing the button displays the screen with information relating to online registration for the *mySOLARFOCUS app* (serial number, PIN, status, etc.) > Fig. 2-40, page 28

Detailed information on using the *mySOLARFOCUS app* > 27

5.4.6.5 Language selection



Fig. 2-22

5.4.6.6 Date and time

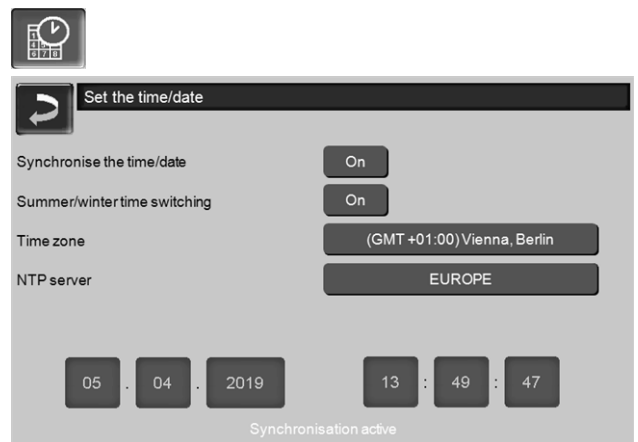

Fig. 2-23

switchover from summer/winter time is made automatically when the *Switchover Summer-Winter 1* parameter has the value Europe. Switchover takes place on the last Sunday of the months of March and October. If *America* is set, the clock is changed to summer time on the first Sunday in April.

6 Heating circuit

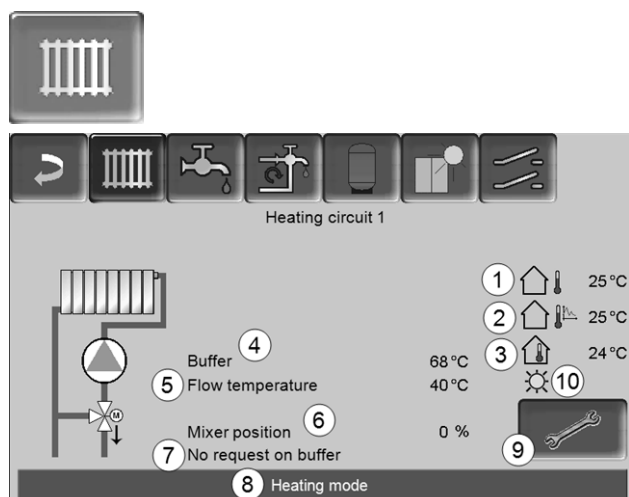

Fig. 2-24

- 1 Outside temperature
- 2 Average outside temperature
- 3 Room temperature (optional)
- 4 Temperature of the energy source, (e.g. boiler, buffer)
- 5 Flow temperature of the heating circuit
- 6 Position of the heating circuit mixer
0% - the mixer is closed, the heating circuit is supplied from the heating circuit return. 100% - the mixer is open, the heating circuit is supplied from the heating boiler flow.
- 7 Info line: Heating requirement (Yes/No) to the energy source.
- 8 Status line of the heating circuit
- 9 Heating circuit settings > 18
- 10 Display of the heating circuit operating mode set on the optional room temperature controller (Art. no. 6160)



6.1 Heating circuit settings

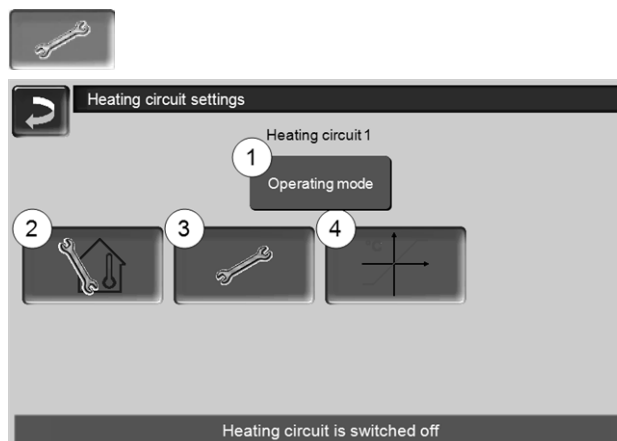

Fig. 2-25

- 1 Heating circuit operating mode > 18
- 2 Room settings
(Button is only visible when the *Room effect* parameter is set to *On* or *Sliding*; this can be found in the *Specialist personnel system parameters*)
- 3 General settings > 19
- 4 Heating curve > 19

6.1.1 Heating circuit operating mode

Heating mode

The heating circuit pump is activated. A shutdown occurs whenever

- the *external shutdown temperature for heating mode* is reached
- when a room temperature sensor is used and where *room nominal temperature for heating mode* has been reached.

The heating circuit is supplied with the *calculated inlet nominal temperature* > Fig. 2-26.

Reduced mode

Heating circuit pump is activated. A shutdown occurs whenever

- the *external shutdown temperature for reduced mode* is reached.
- a room temperature sensor is used and where *room target temperature for reduced mode* has been reached.

The heating circuit is provided with the reduced temperature, i.e. *calculated inlet nominal temperature* minus *reduction*; > Fig. 2-26.

Time switching

In this operating mode, the timed switch-over between *Heating mode* and *Reduced mode* is defined. You can enter the times for heating mode *Daily* or *In blocks*.

Usage example: *Heating mode* should be active during the day, but be changed to *reduced mode* at night.

Switch off heating circuit

The heating circuit pump and heating circuit mixing valve are switched off. The anti-freeze function for the heating circuit is enabled (i.e. the heating circuit pump is switched on whenever the ambient temperature drops below the *anti-freeze temperature*).

Holiday mode

Holiday mode deactivates the active operating mode for the entered duration.



activates the frost protection mode for the heating circuit for the duration of the holiday.



activates the reduced mode for the heating circuit for the duration of the holiday.



This icon indicates an activated holiday mode in the *heating circuit* screen.

6.1.2 General settings



Cutoff temperature

If the outdoor temperature exceeds the value set here, the heating circuit pump is switched off and the heating circuit mixer closes.

Cutoff temperature for heating mode: 18°C

Cutoff temperature for reduced mode: 5°C



This means: the heating circuit is normally automatically switched off during the summer month due to the outdoor temperature.

You can also switch the heating circuit off manually (=operating mode: Switch off heating circuit).

Anti-freeze temperature

If the outdoor temperature drops below the value set here, the heating circuit pump is switched on.

Buffer difference

The burner starts when the tank temperature top falls below the required flow temperature minus the buffer difference.

Example:

- Current flow required temperature = 50°C

- Buffer difference = 5°C

The burner starts as soon as tank temperature top < 45°C.

A negative buffer difference value is added, i.e. the burner starts earlier.

Example:

- Current flow required temperature = 50°C

- Buffer difference = - 5°C

The burner starts as soon as tank temperature top < 55°C.

Ext. temperature delay

The delay set here is used to determined an average value for the outdoor temperature (= Average outdoor temperature).

The heating circuit pump switches on if the Average temperature and the Current outdoor temperature fall below the cutoff temperature (within the heating period), or below the reduced mode cutoff temperature (outside the heating period).

The heating circuit pump switches off again as soon as the current outdoor temperature rises above the value of the cutoff temperature.

Heating circuit name

Individual naming of the heating circuit is possible.

6.1.3 Heating curve

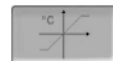

The heating circuit flow temperature is controlled by the heating circuit operating mode > 6.1.1 and by the outdoor temperature. The heating curve represents the relationship between these two temperatures. I.e. the control unit uses the outdoor temperature to calculate the temperature (=calculated nominal flow temperature) with which the heating circuit is supplied.

In *heating mode* the heating curve for heating mode 4 (red) is used.

In *reduced mode* the heating curve for reduced mode 5 (= heating curve for heating mode minus *reduction*) is used.

The heating curve must be adapted to suit each building and its heating system.

2-point heating curve

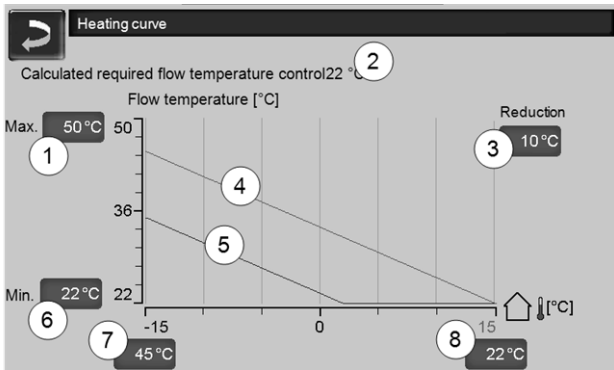

Fig. 2-26

- 1 Maximum heating circuit flow temperature^[1]
- 2 Calculated required flow temperature
- 3 Reduction (the value by which the reduced temperature is lower than the heating temperature)
- 4 Heating curve for heating mode (shown in red)
- 5 Heating curve for reduction mode (blue)
- 6 Minimum heating circuit flow temperature^[1]
- 7 Flow temperature at outside temperature -15°C
- 8 Flow temperature at outside temperature +15°C

! **1) CAUTION** - This temperature is system-specific and must be agreed with the heating engineer. If there is a risk of the boiler overheating, the hot water is discharged to the heating circuits at the *Maximum heating circuit flow temperature 1*. Only to be set by qualified personnel.

The desired heating circuit nominal flow temperature in heating mode is set for an outside temperature of -15°C **7** and +15°C **8**. Between these outside temperatures, the nominal flow temperature is calculated from the characteristics of the heating curve (interpolated).

Example for calculation of nominal flow temperature (see the following illustration):

Flow temperature at outside temperature of -15°C = 45°C

Flow temperature at outside temperature of +15°C = 22°C

Current external temperature = -5°C

In the heating circuit operating mode *Heating mode*, this applies:

> The computed flow nominal temperature (**Pos.9**) is 37.4°C

> The heating circuit is supplied with 37.4°C.

In the heating circuit operating mode *Reduced mode*, this applies:

Reduction = 10°C

> The computed flow nominal temperature (**Pos.10**) is 27.0°C

> The heating circuit is supplied with 27.0°C.

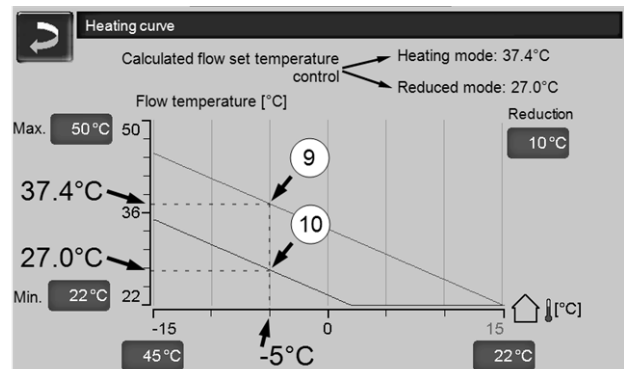

Fig. 2-27

Adaptation of the 2-point heating curve (in *heating mode*)

i Note the currently set temperature before you change the values.

A change in heating curve cannot be felt immediately. Instead, this depends largely on the kind of heat distribution system (e.g. underfloor heating) and the building standard (brick, lightweight construction etc.). It is advisable to adapt the heating curve in small increments (+/- 2°C) with corresponding pauses (1 to 2 days). Depending on the current outside temperature, different adjustments need to be made.

Current Outside temperature	Perceived room temperature	Recommended adaptation of heating curve
-15°C to -5°C	too cold	Increase temperature value at 7
	too hot	Reduce temperature value at 7

Current Outside temperature	Perceived room temperature	Recommended adaptation of heating curve
-5°C to +5°C	too cold	Increase temperature value at 7 and 8
	too hot	Reduce temperature value at 7 and 8
+5°C to +15°C	too cold	Increase temperature value at 8
	too hot	Reduce temperature value at 8

3-point heating curve

i Function must be activated by qualified personnel.

Depending on the standard of building and insulation, it is advisable to change over from the 2-point to a 3-point heating curve. In contrast to the 2-point heating curve, it is possible to stipulate a third temperature **11**, i.e. the heating curve can include a sharp deflection or bend.

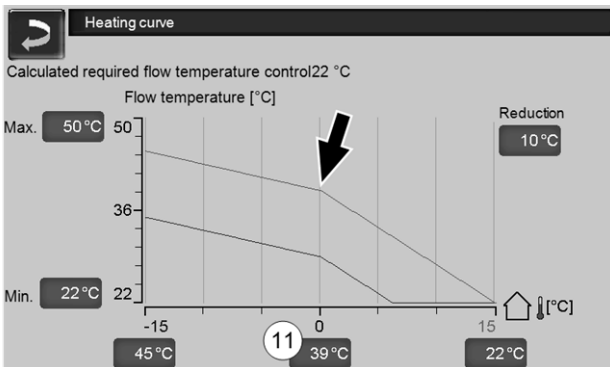

Fig. 2-28

Adaptation of the 3-point heating curve (in heating mode)

i Note the currently set temperature before you change the values.

Current Outside temperature	Perceived room temperature	Recommended adaptation of heating curve
-15°C to -5°C	too cold	Increase temperature value at 7
	too hot	Reduce temperature value at 7
-5°C to +5°C	too cold	Increase temperature value at 11
	too hot	Reduce temperature value at 11
+5°C to +15°C	too cold	Increase temperature value at 8
	too hot	Reduce temperature value at 8

7 DHW heating



DHW can be heated up in two ways:

- With a *DHW tank* > 21 the energy source of the DHW tank is the heating boiler or a buffer tank^[1]
- With a *fresh water module* > 22 (The energy source of the fresh water module is a buffer tank^[1])

i ^[1]DHW area in the buffer tank
Warm water rises and collects in the uppermost area of the buffer tank (= thermal stratification). The DHW tank or the fresh water module draws the required energy for DHW heating from this uppermost area. Therefore, this (held at an adjustable temperature level) area in the buffer tank is also referred to as the *DHW area*.

7.1 Domestic hot water tank

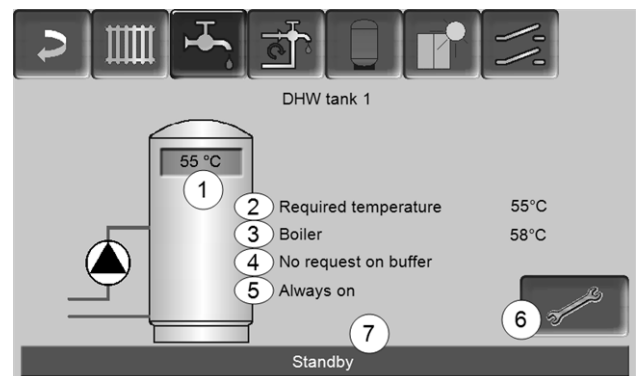

Fig. 2-29

- 1 DHW tank temperature
- 2 Required DHW tank temperature
- 3 Temperature of the energy source (e.g. boiler, buffer tank)
- 4 Info line: Charging requirement (Yes/No) to the energy source.
- 5 DHW tank operating mode > 22
- 6 DHW tank settings > 22
- 7 Status line DHW tank

7.1.1 DHW tank settings

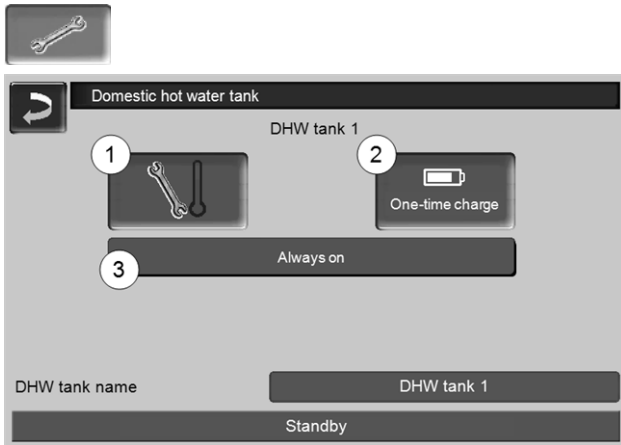

Fig. 2-30

- 1 Temperatures and hystereses 1
- 2 One-time charge 2
- 3 DHW tank operating mode 3

Temperatures and hystereses 1



Required temperature / hystereses

The DHW (or the domestic hot water area in the buffer tank) is charged when required until the set *Required temperature 1* is reached. A new charge starts when the DHW tank temperature falls to the value *Required temperature 1* less *Hysteresis*.

Example

- Required temperature 1 = 55°C
- Hysteresis = 10°C

The DHW charge starts when the DHW temperature falls to 45°C (requirement: The temperature of the energy source is 5°C above 45°C).

One-time charge 2

Is used to perform one-off re-heating of the DHW tank (e.g. if no release times are defined or the operating mode *Always Off* is set). By pressing the button, the DHW tank is recharged as soon as a charging request is made by the DHW tank.

DHW tank operating mode 3

Always off: The DHW tank charge pump is switched off permanently.

Exception for frost protection mode: The DHW tank charging pump is activated if

- the outside temperature is <math>< 2^{\circ}\text{C}</math>, and
- the DHW tank temperature goes to <math>< 10^{\circ}\text{C}</math>.

Always on: The DHW tank charge pump is switched on permanently. The pump is controlled taking the parameters *Required temperature 1*, *Minimal temperature* and *Hysteresis* into account.

Time switching (*Monday-Sunday, daily,...*): different time ranges can be set, in which the DHW tank charge pump is switched to *ON*.

-  The operating mode *Monday - Sunday* and is not available if you are using the *mySOLARFOCUS app* > 27.

7.2 Fresh water module - FWM (optional)

A fresh water module heats domestic hot water in the continuous flow principle. The circulation pump of the fresh water module starts if a DHW output point (also called a *tapping point* e.g. shower or batch, etc.) is opened. The energy for heating up domestic hot water is taken from the upper area (called the *DHW area*) of the buffer tank.

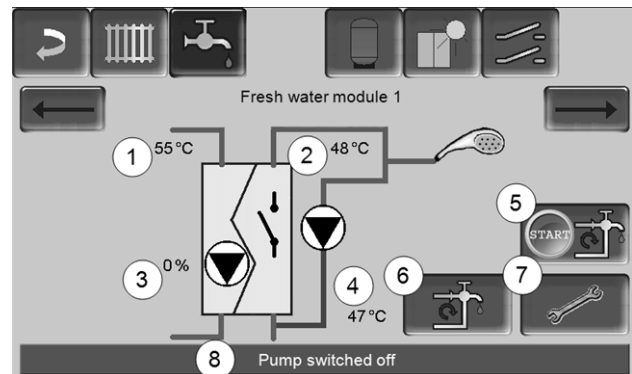

Fig. 2-31

- 1 Buffer tank temperature
- 2 Required DHW temperature
- 3 Speed of the fresh water module pump
- 4 Recirculation temperature ^[1] (only visible if a recirculation sensor is connected).
- 5 Start recirculation pump ^[1] (serves for immediate start of the recirculation pump)
- 6 Circulation pump settings ^[1] > 23
- 7 Fresh water module settings > 23
- 8 Fresh water module status line

¹⁾ Recirculation control is an optional additional function.

Fresh water module settings 7



Pump control

Always off: The fresh water module pump is permanently switched off; no domestic hot water is heated up.

Always on: (= manual mode); the fresh water module pump is always switched on.

Automatic (= default setting), the fresh water module pump starts when a flow is detected in the pipework by an electronic sensor (e.g. the tap is opened at a consumer).

Required DHW temperature

This parameter is only active in the case of release type *Automatic*. The fresh water module regulates the temperature at which the connected hot water devices receive water.

8 Recirculation control



(optional additional function)

A recirculation line means that hot water can be quickly available at the extraction points (also called tapping points, e.g. basin, shower, bath, ...), even with long supply pipes.

Recirculation control is possible with a fresh water module or for a DHW tank.

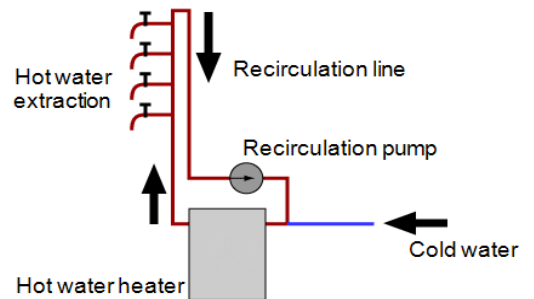

Recirculation screen

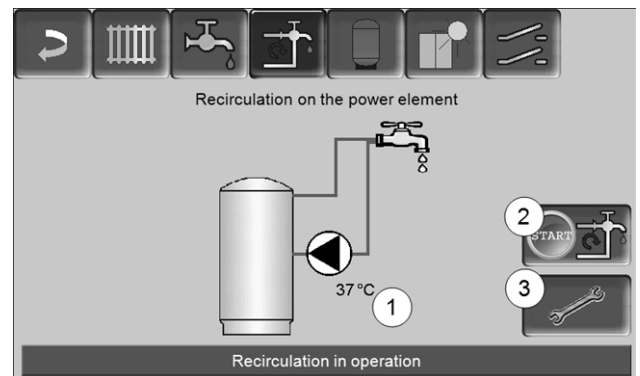

Fig. 2-32

- 1 Recirculation temperature (only visible if a recirculation sensor on the boiler power element is connected).
- 2 Start recirculation pump (serves for immediate start of the recirculation pump).
- 3 Circulation settings

8.1 Circulation settings

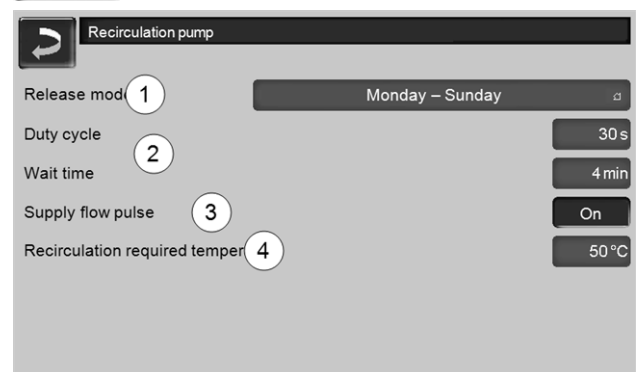

Fig. 2-33

Release mode 1

Always off: The recirculation control is switched off permanently.

Always on: The recirculation control is switched on permanently. The recirculation pump is only triggered in consideration of the parameters *Switch-on duration* and *Hold-on time*.

Time switching (*Monday-Sunday, in blocks, ...*): In this respect, time releases can be set for recirculation control.

Switch-on duration / Hold-on time 2

Depending on the recirculation control selected, the pump is cycled in consideration of these two parameters, i.e. alternation between *Switch-on duration* and *Hold-on time*.

Recirculation required temperature 4

Is the required temperature in the recirculation line (only displayed when a recirculation sensor is connected).

8.2 Recirculation control - Options



In order to be able to make use of the following controls, time switching (*Monday-Sunday, in blocks, etc.*) must be selected for the parameter *release type*.

Time-controlled recirculation

In the event of time-controlled recirculation, the recirculation pumps are triggered on a cycled basis if a time release (see parameter *release type* 1) is present. Cycling (i.e. switching between control/no control) is conducted in accordance with the *Switch-on duration* and *Hold-on time* parameters.

Example:

- Release type = *Monday-Sunday*,
- The recirculation control currently has, for example, a time release of 06:00 to 08:00
- Switch-on duration = 30 seconds
- Hold-on time = 4 minutes

The recirculation pump runs for 30 seconds. After this, the pump pauses for 4 minutes in order to then run for 30 seconds again. This repeats in a time release from 06:00 to 08:00. Outside the time release, the pump is not triggered.

Temperature- and time-controlled recirculation

Temperature-controlled recirculation is only available if a temperature sensor is connected for the recirculation temperature. The control takes the recirculation temperature (*required recirculation temperature*) into account within the time release. This means that the pump is only cycled if the recirculation temperature is below the *required recirculation temperature* of minus 5°C.

Example:

- Release type = *Monday-Sunday*
- The recirculation control currently has, for example, a time release of 06:00 to 08:00
- Switch-on duration = 30 seconds
- Hold-on time = 4 minutes
- Required recirculation temperature = 50°C
- Recirculation temperature = 48°C

The recirculation pump is not triggered as the recirculation temperature (48°C) is above the *required recirculation temperature* of minus 5°C (50°C minus 5°C = 45°C). If the recirculation temperature goes below 45°C, the recirculation pump is triggered for 30 seconds. After this, the pump pauses for 4 minutes in order to then run for 30 seconds again. This repeats until the recirculation temperature reaches the *required recirculation temperature*. Outside the time release, the pump is not triggered.

Extension of recirculation by means of a flow impulse

Recirculation being controlled by a flow impulse 3 is only possible in fresh water modules > 22, and is used as an extension of the control options previously named.

In order to activate this function, the *Flow Impulse 3* parameter must be set to *on*. When a hot water extraction point is opened briefly, an electronic sensor detects the pressure drop in the line. The recirculation pump is triggered even if there is no time release.

Exception: If a temperature sensor for the recirculation pump (=recirculation sensor) is connected and the recirculation temperature is sufficient (see *Temperature- and time-controlled recirculation*), then the recirculation pump is not triggered.

Exception: If a temperature sensor for the recirculation pump (=recirculation sensor) is connected and the recirculation temperature is sufficient (see *Temperature- and time-controlled recirculation*), then the recirculation pump is not triggered.

Example:

- Release type = *Monday-Sunday*
- No time release has been set.

As soon as DHW is drawn, the recirculation pump is triggered.

9 Buffer tank

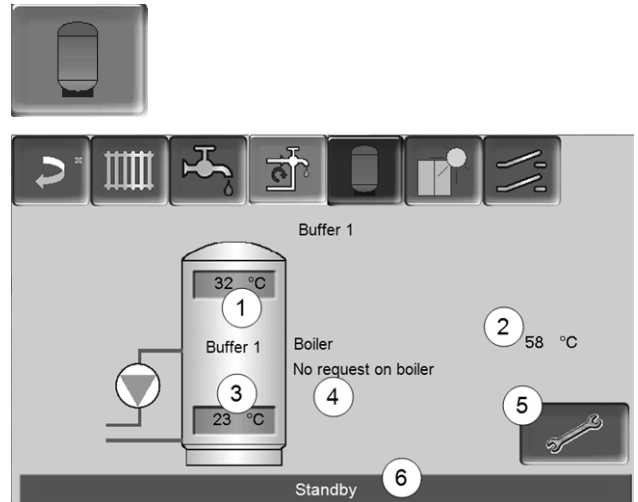

Fig. 2-34

- 1 Buffer cylinder temperature top
- 2 Temperature of the energy source
- 3 Buffer cylinder temperature bottom
- 4 Info line: Heating requirement (Yes/No) to the energy source.
- 5 Buffer tank settings
Button is only visible when *Timer* is selected as the buffer cylinder operating mode; may be adjusted by qualified personnel only.
- 6 Buffer tank status line

Set buffer tank temperatures



Min. buffer temp. top

When *Buffer cylinder temperature top* falls below this value, the energy source for the buffer cylinder starts (e.g. boiler) and the buffer cylinder is re-charged (upon time release).

Max. buffer cylinder temp. bottom

The buffer tank is charged until the *Buffer tank temperature bottom* has reached this value.

- i** In order to ensure optimum and efficient use of the buffer tank, the difference between these two temperatures should be > 15°C.

10 Solar system

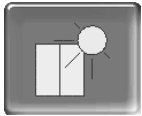

(optional additional function)

The solar yield is loaded into a solar tank. This tank can be a buffer tank or a DHW tank.

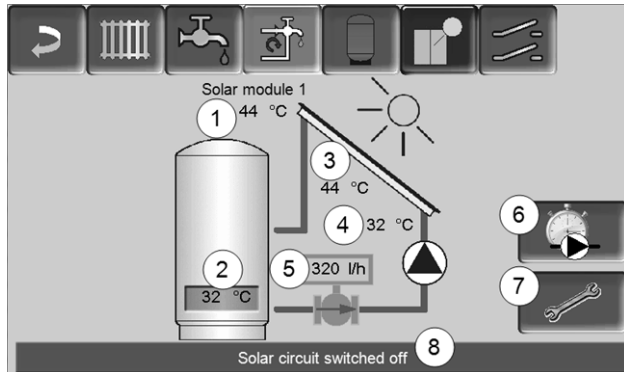

Fig. 2-35

- 1 Collector temperature (measured at the collector sensor)
- 2 Tank temperature bottom
- 3 Collector flow temperature
- 4 Collector return temperature
- 5 Solar circuit flow rate
- 6 Operating hours counter
- 7 Solar circuit settings
- 8 Solar circuit status line

i Additional information on the solar functions, for which a charge is due, (e.g. boiler control of two or three solar circuits) will be provided in a separate manual upon purchase, DR-0007.

i The solar yield is displayed in the *mySOLARFOCUS app* > 27 (prerequisite: A solar system controlled by the *controleco^{manager-touch}*, including thermal unit counter).

11 Temperature difference charge control



(optional additional function)

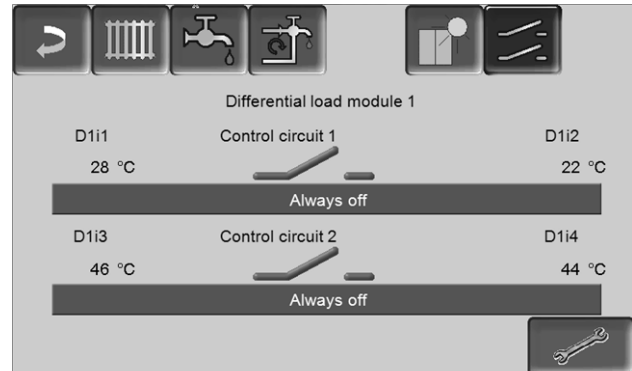

Fig. 2-36

- This function expands the control *eco^{manager-touch}* with two (independent) differential control circuits. Suitable, for example, for charge pump control systems, for (rapid) tank charge, or return-stratification in the tank.
- The components of this charging circuit (e.g. circulation pump, motor valve, etc.) can be regulated by means of temperature differences between sensors.

i Further information can be obtained in a separate set of instructions when you purchase this function, DR-0014.

12 mySOLARFOCUS app



Function: The *mySOLARFOCUS app* allows you to use your smartphone to access specific control **eco**_{manager-touch} functions:

- Setting the room temperature and heating circuit flow temperature, including heating times.
- Hot water programs, with one-time hot water tank loading.
- Display of the solar yield of your solar power system.

i Installation and configuration of this function must be performed by the customer (i.e. not included in the commissioning, service and support activities).

12.1 Requirements for use

- The software version of the control is $\geq V 15.080$; for **octo**_{plus}, **pellet**_{elegance}, **pellet**_{top}, Central control **eco**_{manager-touch}.
- The control must be connected to the internet.
- Smartphone with Apple IOS 7.0 or Android OS 4.4

12.2 Connecting the control to the internet

Create a connection between the router and the boiler control panel (touch display)

Use the following socket (RJ45) on the rear of the display:

- for the boilers **octo**_{plus}, **pellet**_{top}, and **pellet**_{elegance}, Central control **eco**_{manager-touch}
 - with 7-inch display: *X2 Ethernet*
 - older version, with 5.7 inch display: *X4 Ethernet*

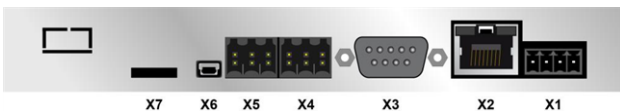

IP configuration



- ▶ To access the *IP-VNC* icon, select it in the control
 - *Selection menu* screen
 - *Customer menu* screen
- Trained qualified personnel button

- ▶ Enter the data for your router. Recommend process:
 - Select *DHCP ON*.
 - The IP address is determined.
 - Select the *DHCP OFF + Apply button*.

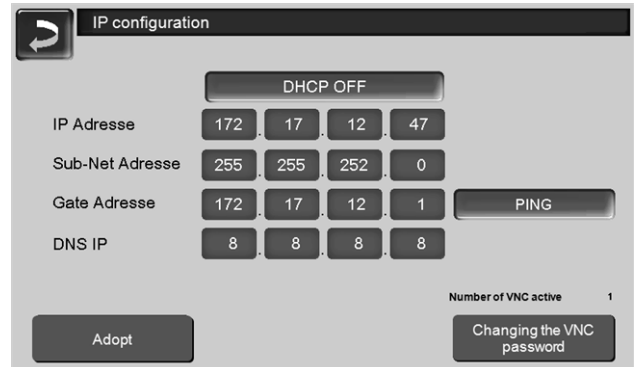

Fig. 2-37

- The IP address must be unique in each Ethernet network and is dependent on the other network components (PC, modem/router, etc.).
- Recommendation: Set a fixed IP address (=DHCP OFF), i.e. the control unit has a constant IP address.

12.3 Register on the web server

The touch display must be registered on the SOLARFOCUS Web server:

- ▶ Press the app button

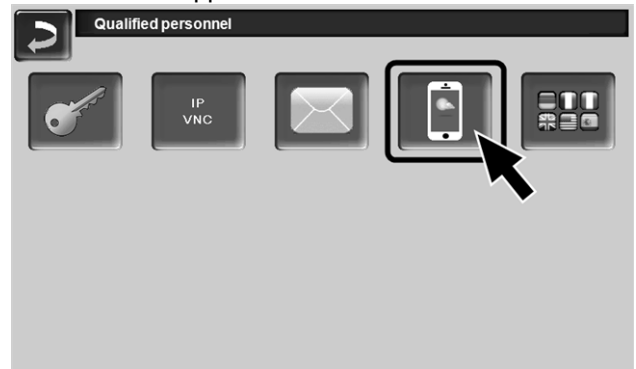

Fig. 2-38

- ▶ Continue by pressing *Accept*

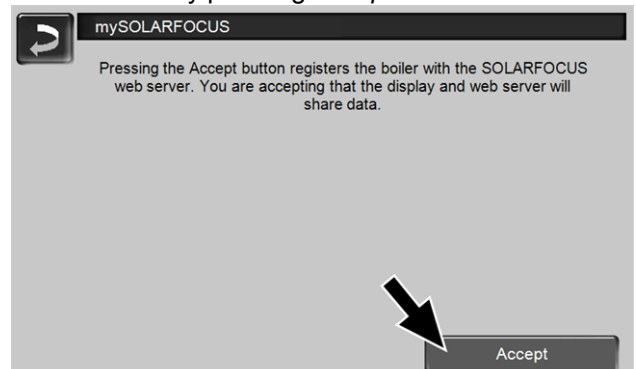

Fig. 2-39

- ▶ Note the serial number and PIN
- ▶ Switch the *Send data parameter* to *Yes*.

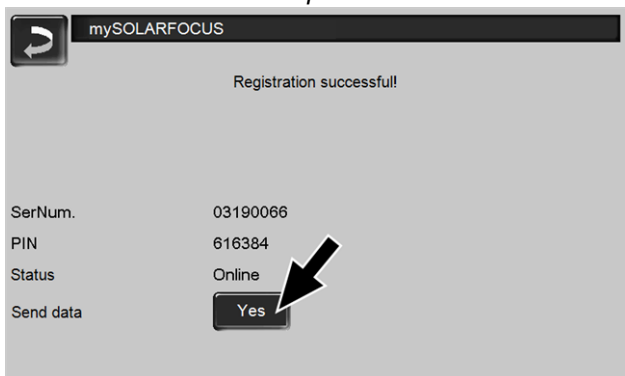

Fig. 2-40

If the connection is faulty, possible causes include:

- ▶ Check the connection from the display to the router.
- ▶ Check the IP addresses you have entered.
- ▶ Check your network router (e.g. status, etc.).

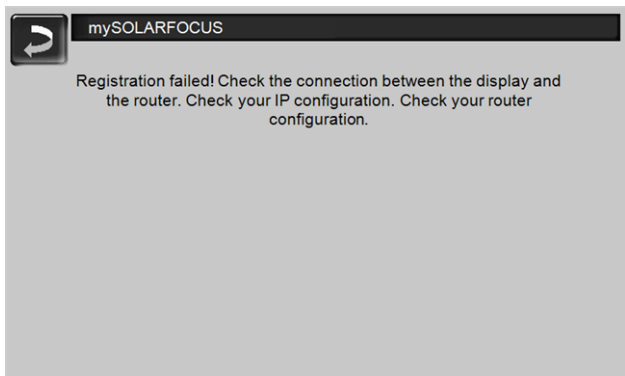

Fig. 2-41

12.4 Install app, register user



The *mySOLARFOCUS app* is available in the Apple Store and Google Play Store.

- ▶ Download, install and start the app.

- ▶ Press the *Register new user* button.

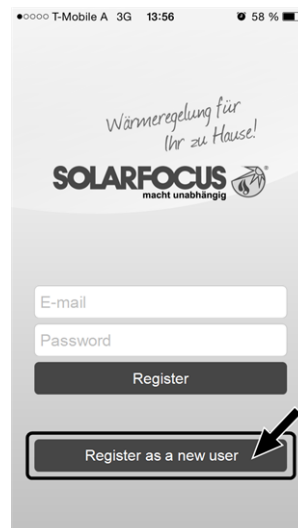

Fig. 2-42

- ▶ Enter the information required and press the *Register* button.
 - ↳ An email will be sent to the email address you provided.
- ▶ Open the email and click on the *Confirm account* link.
 - ↳ You can now sign into the app (to sign in, enter your email address and password).

12.5 Add system

- You have successfully signed into the app.
- ▶ Press the *Add new system* button.

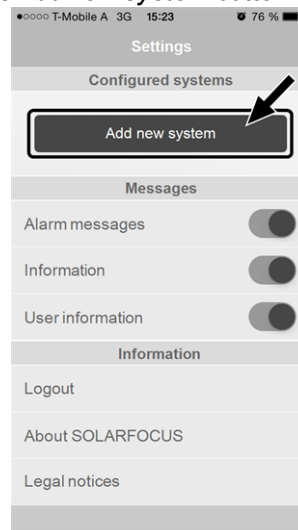

Fig. 2-43

- ▶ Enter the data for your heating system (serial number and PIN).

i The weather forecast data for the weatherman function are sent to the boiler control on the basis of the Postcode and Location fields.

i As an alternative to the app, you can also add systems on the website:
<https://www.mysolarfocus.com>

i Important: In principle only *one* user may access a system. If additional users wish to access a system, then they must be approved in advance *Approve additional users > 29*.

12.6 Use of the mySOLARFOCUS app



In the boiler control, the app icon indicates that the parameter has been changed on the basis of an entry in the app; e.g.

- in the *heating circuit* screen: If *short-term mode* has been activated in the app.
- in the *heating circuit* screen, in *room settings*
- in the *heating curve* screen

Changes using the app:

- In the heating circuit screen, only *Daily time switching* is available in heating circuit mode, and not *In blocks*.
- In the *heating domestic hot water* screen, the time switches Monday - Sunday and *In blocks* are not available for DHW tank mode.

12.7 Approve additional users

You can enable access to your control for additional users, for example heating engineers.

Issuing approval.

- ▶ Select the *Approval* menu item.

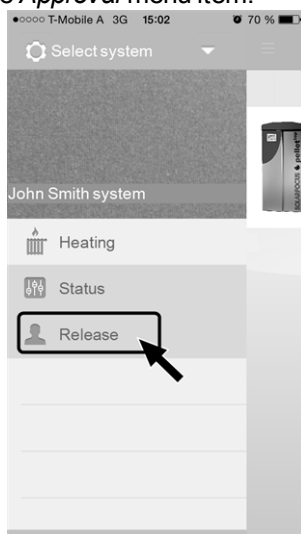

Fig. 2-44

- ▶ Enter the user's email address and select the *Invite* button.
 - ↳ The invited user will receive an email with an approval code for the system. He can use this to add the system to his app account.

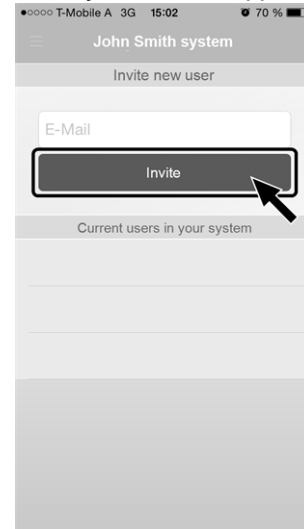

Fig. 2-45

13 Weatherman function



Function: The control **eco**^{manager-touch} receives current weather forecast data on an ongoing basis. If good weather is forecast, then the control delays starting the burner when there is a heating request.

The requirements for using the weatherman function are as follows:

- The software version of the control is $\geq V 15.080$; for **octo**^{plus}, **pellet**^{elegance}, **pellet**^{top}, Central control **eco**^{manager-touch}, Central control **eco**^{manager-touch}
- Registration of the heating boiler on the web server SOLARFOCUS, or in the *mySOLARFOCUS app*, > 27.

After successful online registration of the heating system, after approx. 2 to 3 hours, the 'weatherman' button **1** is displayed in the *Selection menu*.

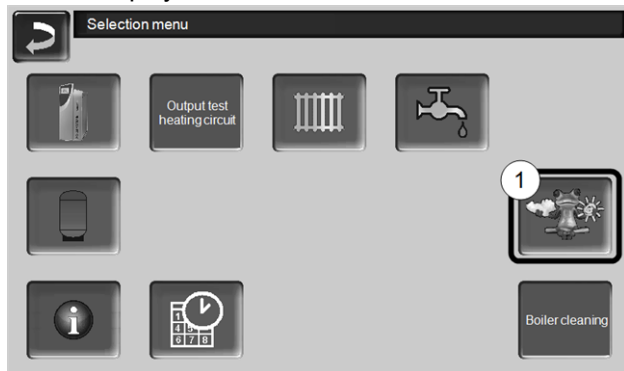

Fig. 2-46

Press the button **1** to access the weatherman menu.

If you cannot see the button, check the following (see *mySOLARFOCUS app*, > 27).

- Has your heating system been correctly registered on the SOLARFOCUS web server?
- Is the connection status between the control and the SOLARFOCUS web server *online*?
- Is the *Send data parameter* set to *Yes*?

13.1 Information

The *weatherman information* menu visualises the current weather forecast.

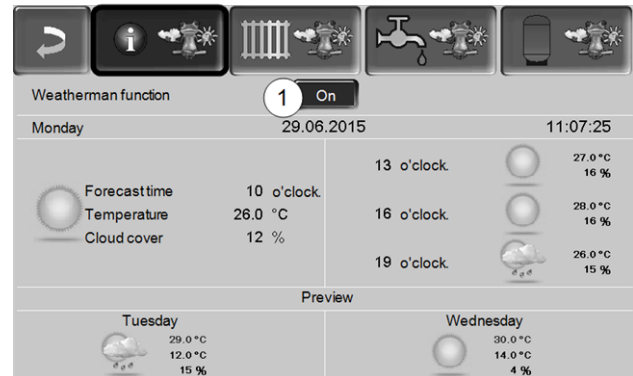

Fig. 2-47

Weatherman function 1

Off: The weather forecast is shown in the display, but does not influence the control at all.

On: The weather forecast influences the behaviour of the control in the menus

- Heating circuit
- DHW heating
- Buffer tank

The following applies for three menus: The level of influence can be set using the plus/minus buttons on the bars, in 10 % steps,



- 0% means that good weather being forecast has no influence on the control of the heating circuit/domestic hot water/buffer tank charging.
- 100% means a maximum level of influence.

13.2 Heating circuit

This menu **1** is only visible when a heating circuit in the boiler control is enabled.

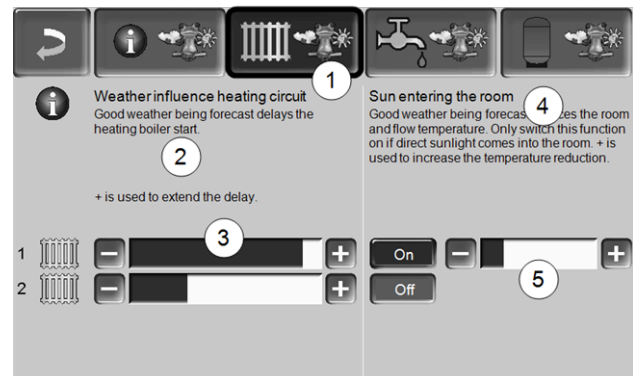

Fig. 2-48

Weather influence heating circuit 2

This area is only visible when the heating circuit obtains its energy from a buffer tank enabled in the control.

Activate the *weather influence heating circuit function* only if the buffer tank is connected to a solar power system.

Good weather being forecast delays the start of the burner in the event of a request from the heating circuit. The bar 3 can be used to set the duration of the request delay for each heating circuit individually.

0% = no delay to burner start.

100% = maximum delay to burner start in the event of good weather being forecast.

If the function delays burner start due to good weather being forecast, then the weatherman icon appears in the main heating circuit menu.



The green column indicates the delay. When 100% is reached, the burner starts.

Solar yield in the room 4

Activate this function only if solar radiation directly influences the heating circuit (e.g. solar radiation through a glass panel).

Good weather being forecast means that

- the flow temperature of the heating circuit is reduced (within the heating period),
- the room temperature is reduced (if the *Room influence* parameter is activated in the heating circuit menu).

The bar 5 can be used to set the temperature reduction for each heating circuit individually.

0% = no reduction in the heating circuit flow temperature, or the room temperature.

100% = maximum reduction in the heating circuit flow temperature, or the room temperature, in the event of good weather being forecast.

Within the heating period, the heating circuit flow temperature is reduced by a maximum of the *reduction* set in the *heating curve* screen.

Within the heating period, the inside setpoint temperature is reduced as a maximum to the inside setpoint temperature reduced mode set in the heating circuit room settings screen.

If the *Solar yield in the room* reduces the temperature (s) due to good weather being forecast, then the weatherman icon appears in the main heating circuit menu.



13.3 Domestic hot water

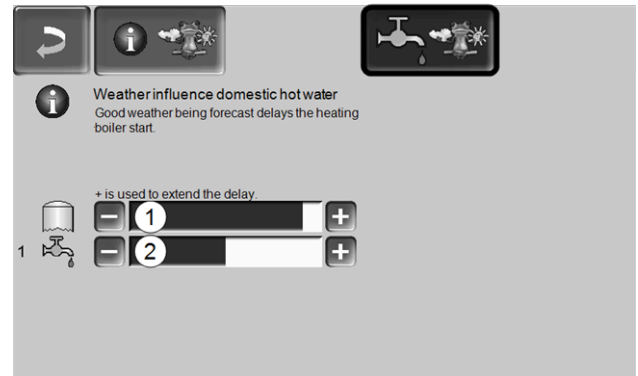

Fig. 2-49

1 DHW range for the boiler **octo plus**

2 DHW tank / domestic hot water area 1 to 4

Activate the *weather influence domestic hot water* function only if the DHW tank/domestic hot water area is heated by a solar power system, or is charged from a buffer tank that is heated by a solar power system.

Good weather forecast delays the start of the burner in the event of a request from the DHW tank/domestic hot water area.

The bar can be used to set the duration of the request delay for each DHW tank/domestic hot water area individually.

0% = no delay to burner start.

100% = maximum delay to burner start in the event of good weather being forecast.

If the function delays burner start due to good weather being forecast, then the weatherman icon appears in the main domestic hot water menu.



The green column indicates the delay. When 100% is reached, the burner starts.

13.4 Buffer tank loading

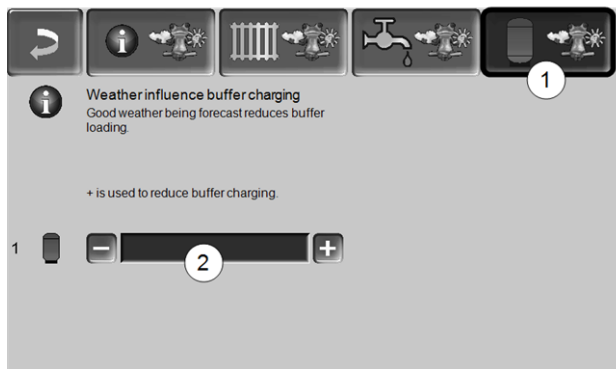

Fig. 2-50

This menu **1** is only visible when a buffer control in the boiler control is enabled.

In the event of good weather being forecast, the buffer tank is charged for a shorter time within the time release.

The bar **2** can be used to set the level of influence for each buffer tank individually.

0% = if the burner has started and the buffer tank is within a time release, the buffer tank is completely charged. The charge request is fulfilled when the *buffer temperature, lower*, has reached the *maximum buffer temperature, lower* (in the buffer tank main menu).

100 % = if the burner has started and the buffer tank is within a time release, the buffer tank is not completely charged. The charge request is already fulfilled when the *buffer temperature, lower*, has exceeded the *minimum buffer temperature, upper* (in the buffer tank main menu).

14 Maintenance (and cleaning)

- i** Regular maintenance of the heating system is a prerequisite
 - for permanently reliable functioning of the boiler,
 - for energy-saving and environmentally friendly operation of the boiler,
 - for a long service life of the boiler.

Basic information on boiler maintenance (including cleaning activities):

- Part of the boiler cleaning is done automatically in the boiler > 32
- Some activities must be done manually.

On the following pages you will find an overview > 33 of these manually required activities:

- What activities have to be performed
- At what time interval must this activity take place
- Who is responsible for carrying out the respective activity

Boiler cleaning - automated processes

The following processes are carried out automatically by the boiler control at regular intervals:

- Clean the turbulators **1** by rotating the inside of the heat exchanger, whereupon the ash falls into the combustion chamber **2**.
- The ashes from the burnt pellets fall through the stainless steel combustion grate **3** into the combustion chamber. The ash roller **4** transports the ashes into the ash container below (this ash container must be emptied regularly).

Deashing in the boiler

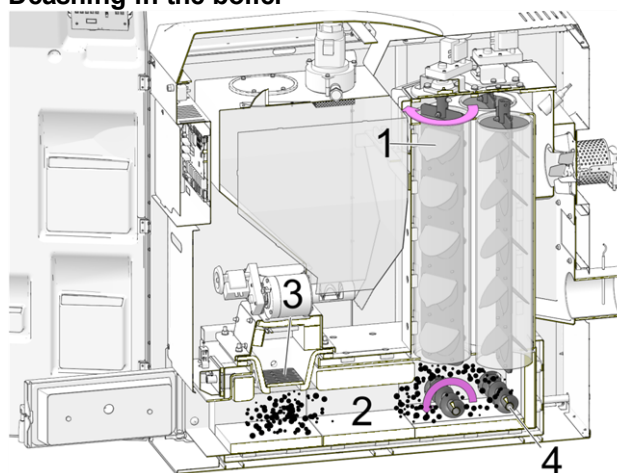

Fig. 2-51: Section through the boiler

14.1 Required activities - overview

The implementation responsibility of the maintenance activities is defined according to type and extent (system operator *SO* or qualified personnel *QP*).

Activity	Interval	AB	FP
Empty ash container > 33	upon notification message	X	
Perform boiler cleaning > 34 – Check the stainless steel combustion grate for wear > 34 – Check the stainless steel combustion grate support > 34 – Remove ash from the combustion chamber > 34	monthly ^[1] [2]	X	
Check system pressure > 35	monthly	X	
Clean flue gas pipe > 35	yearly	X	
Check safety valve > 35	yearly	X	
Replace pellet suction turbine > 35	After approx. 800 operating hours		X
Maintenance by qualified personnel > 35	yearly		X
Perform emissions measurement > 36	as per regional regulations		X

[1] Indication is valid for average consumption values; Adjust the interval according to your own requirements.

[2] In the boiler control a message can be set (to be carried out by qualified personnel), with a reminder to perform a boiler cleaning.

 You can use the function *E-Mail Message* > 16 to be informed about an upcoming emptying of the ash container (see *Alarm selection* button)

14.1.1 Empty ash container

Empty the ash container when the message on the boiler control display appears. In the course of emptying the ash container, a boiler cleaning > 34 can also be performed.

Information on required emptying of the ash box:

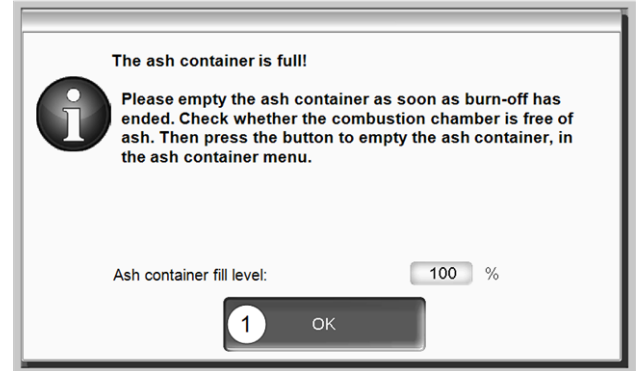



Fig. 2-52

- ▶ Wait until the burner switches off (the burner still fulfils its heating requirements, i.e. this can take longer).
- ▶ Open both lateral turnbuckles on the ash box, remove the ash box, empty it and reattach it.

 **DANGER** - risk of fire due to hot ash self-igniting. Only store removed ash in metal containers with a lid.

- ▶ Confirm the information message on the display with OK 1 > Fig. 2-52
- ▶ Press the *Ash box emptied* 2 button (in the selection menu, ash box button).

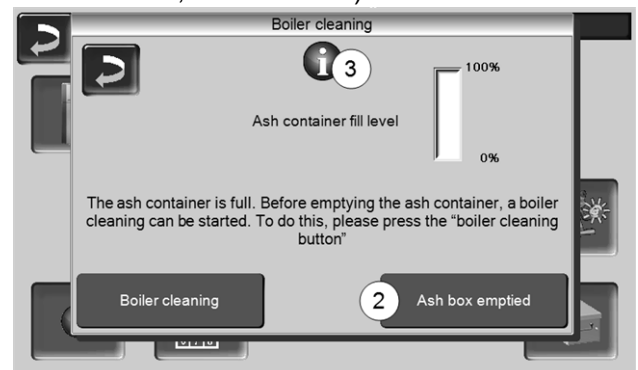

Fig. 2-53

- ↳ The counter for the ash box fill level is reset to zero.

Note: Press button 3 to open the *Boiler cleaning statistics* screen (shows the time of the last 5 boiler cleanings).

14.1.2 Boiler cleaning - manual activities

Two ways to start with the boiler cleaning:

The burner is active

- ▶ Switch the boiler off (press the *STOP* button > 11 and leave to cool.

The boiler is in *standby* status

- ▶ Press the *STOP* button > 11, and if necessary let the boiler cool down.
- ▶ Press the *boiler cleaning* button > Fig. 2-53
- ▶ Perform these activities:
 - Check the stainless steel combustion grate for wear > 34
 - Check the stainless steel combustion grate support > 34
 - Remove ash from the combustion chamber > 34

14.1.2.1 Check the stainless steel combustion grate for wear

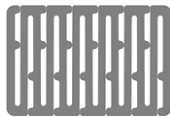

In the event of advanced wear of the stainless steel combustion grate, the spaces in the grate enlarge. A seriously worn stainless steel combustion grate will allow incompletely burned pellets to fall through. Check this regularly if you remove the ash from the combustion chamber; if necessary, replace the stainless steel combustion grate > 34

14.1.2.2 Check the stainless steel combustion grate support

- i** **The stainless steel combustion grate must lie completely flat and horizontally.** When inclined, ignition problems are possible, or this can lead to uneven wear of the stainless steel combustion grate. If necessary, clean the stainless steel combustion grate support surface over the entire circumference and remove any deposits.

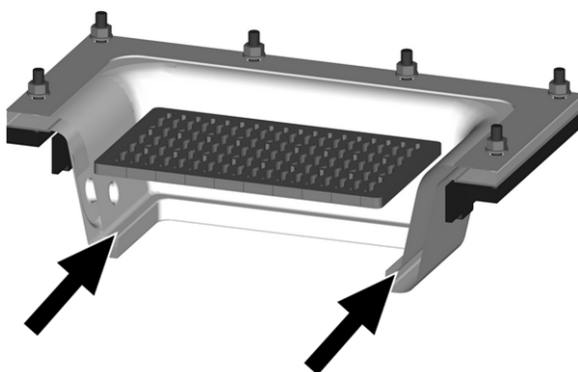

Fig. 2-54: Clean stainless steel combustion grate support surface

14.1.2.3 Remove ash from the combustion chamber

- ▶ Open the cladding door and combustion chamber door.
- ▶ Place the ash pans **1** in front of the combustion chamber.
- ▶ Pull the ash present in the combustion chamber into the ash pan using the ash scraper.

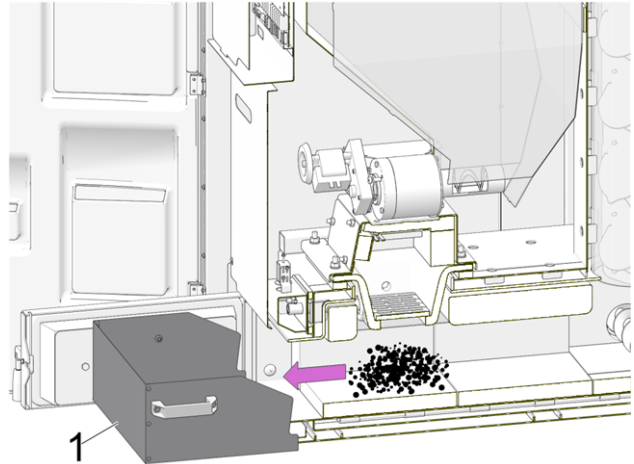

Fig. 2-55: Pull the ash from the combustion chamber into the ash drawer.

14.1.3 Replace combustion grate

- ▶ Switch the boiler to *STOP* > 11 and leave to cool.
- ▶ Open the cladding door, lift the cover plate up and remove it.
- ▶ Remove **1** the cover by releasing the 4 hex nuts M8 (WAF 13).
- ▶ Remove the stainless steel combustion grate **2** upwards, insert a new grate and reinstall the components in the reverse order. Note: Before inserting the stainless steel combustion grate, clean the support surface.

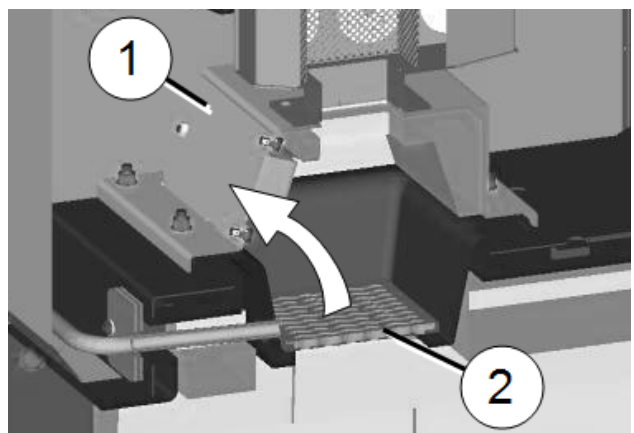



Fig. 2-56: Replace combustion grate

14.1.4 Check system pressure

The water pressure in the heating system can be read on the pressure gauge. As a rule of thumb (for buildings of up to three storeys), the pressure should be 1 to 2 bar for a cold system and 1.5 to 2.5 bar for a hot system.

It is important that the pressure remains constant at all times. A constant fall in pressure requires the addition of extra water and indicates a fault in the system (e.g. a leak).

 TIP: Make a note of the set system pressure during initial commissioning.

14.1.5 Clean exhaust gas duct

The flue pipe is located between boiler and chimney.

- ▶ Remove cover **1** in the flue gas pipe.



- ▶ Remove combustion deposits (e.g. dust, fly ash) from the pipe.

14.1.6 Check safety valve

Carry out a visual check for leaks at the valve (inspect around outlet of dump hose). Turning the valve cap is not recommended, as the valve may not seal completely afterwards.

Information on safety valve > 6

14.1.7 Replace pellet suction turbine

The suction turbine for conveying the pellets is a wearing part. Depending on the degree of soiling^[1] of the suction turbine, the service life of the suction motor carbon brushes is around 300 operating hours for the initial equipment, and another 300 operating hours for the replacement carbon brush set. After approx. 800 operating hours, we recommend replacing the suction turbine.

[1] The cleaner the working air (air in the pellet hose) and cooling air (ambient air sucked in from the room), the longer the service life of the brushes will be.

14.1.8 Maintenance by qualified personnel

Depending on the operating hours (in each case after 1800 hours, fixed value) or a defined duration (in months), the control shows an indication of the necessary professional maintenance of the boiler.

Contact your heating engineer or the SOLARFOCUS *Service Hotline* > 3

Conclude maintenance contract

By purchasing a boiler maintenance agreement, SOLARFOCUS will manage the annual appointment and contact you directly when a maintenance appointment is due.

Information on the maintenance agreement > 41

15 Perform emissions measurement

- The emissions measurement at the boiler is a legal requirement and must be performed by qualified personnel on a regular basis.
- Contact the competent chimney sweep and your heating installer for more information.
- When performing the emission measurement, the chimney sweep function of the boiler control must be used.

Chimney sweep measurement release



The chimney sweep function is available in the boiler operating mode screen > 11

Notes on chimney sweep measurement release

- May only be performed by qualified personnel.
- Do not open the boiler door during the measurement.
- Ensure sufficient heat removal for the boiler (e.g. energy removal to buffer store or heating circuit).
- The removal of heat is increased by opening the heating circuit mixer and by switching on the heating circuit pumps.

Start of the chimney sweep measurement release

- ▶ Press the  button.
 - ↳ The prerequisites for a measurement release are tested.

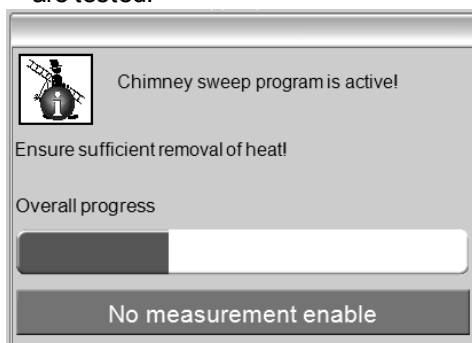

Fig. 2-57

- ▶ As soon as *Measurement enable* appears in the status bar, the measurement can be started.
- The chimney sweep measurement release remains active for a period of 40 min., and before this period expires, a message allowing extension of the period by increments of 30 min in each case is displayed.
- To abort the function prematurely, switch to a different boiler mode.

15.1 Emission measurement for external boilers

If necessary, use the menu *output test heating circuit* > 12 to carry out the emission measurement on an external boiler. In this menu, the electrical outputs for the remote boiler, 3-way motor valve as well as for the heating circuit pump and heating circuit can be switched on/off manually.

16 Filling the pellet store

Switch off the boiler before filling

- ⓘ For safety reasons, switch off the boiler 15 min. before filling (blowing in) the pellet store. By use of the item *House connection box for pellet filling* (item no. 6678) this is done automatically.

17 Troubleshooting

Faults that occur are displayed in an information window in the control and each message is save in the *message log* > 14.

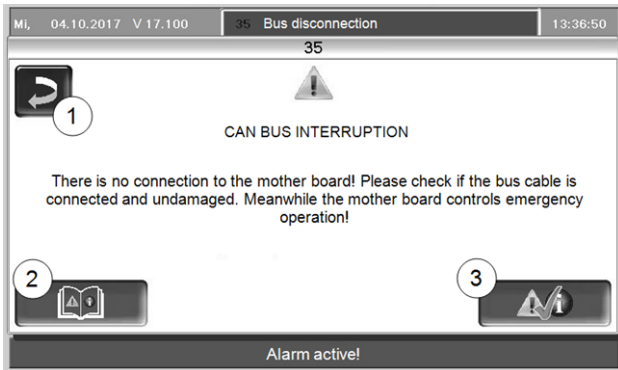

Fig. 2-58: Note window Fault

Handling of messages

- Button **1**: Close window, change to main screen.
The fault message remains active, i.e. the burner may not start depending on the type of message.
- Button **2**: Switch to the *message log*
- Button **3**: Acknowledge the message.
An acknowledgement is only possible if the cause of the fault has been rectified; the burner may then restart after a heating request is received.

An alarm message is visible at the top edge of the main screen until it is acknowledged **1**. Press to acknowledge the message (message window opens)

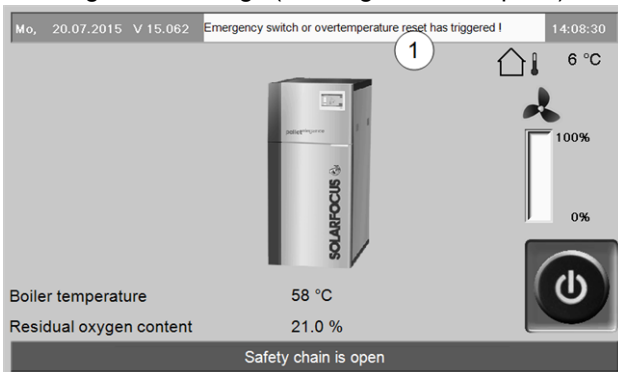

Fig. 2-59

Alarm symbol



This symbol indicates an alarm message: The boiler is no longer ready for operation if such a message occurs.

Note symbol:



This symbol indicates an alarm message: The boiler is still ready for operation.

Possible messages:

In accordance with the prevailing message, it is determined who is supposed to take the required action (system operator *SO* or qualified personnel *QP*).

No.	Message	AB	FP
1	Error in internal memory	x	
2	Feeder sensor short circuit		x
3	Ignition not possible Check the container fill level sensor		x
4	Extraction room may be empty	x	
5	Flue gas temperature too low	x	
	Flue gas sensor interruption		x
7	Flue gas sensor shows wrong measured value		x
8	Feeder sensor interruption		x
9	Flue gas sensor short circuit		x
10	Factory settings loaded		x
11	ID fan error	x	
12	ID fan test running	x	
13	The functionality of the induced draught fan is no longer intact		x
14	Maximum suction time reached	x	
15	Feeder sensor shows the wrong measured value		x
16	Lambda sensor faulty		x
17	Boiler sensor defective		x
18	Boiler temperature is too high		x
19	Extraction auger is blocked	x	x
20	First ignition attempt failed	x	
21	Triac output feeder defective		x
22	Triac output room extraction defective		x
23	DFSH module communication error		x
24	Overtemperature reset or safety chain has been triggered	x	
25	Power failure detected	x	
26	Mains fuse defective		x
27	Triac fuse defective		x
30	Feeder is blocked	x	
31	Heat exchangers are blocked		x
32	Heat exchangers are blocked		x
33	Line interruption to feeder motor		x
35	CAN bus interruption		x
36	Fuse at fresh water module defective		x
37	Fuse on module defective		x
38	Commissioning settings loaded		x
39	Solar setting <i>Max. tank temperature bottom</i> can trip safety temperature limiter	x	x
40	Ignition not possible	x	x
41	Fuse F1 or F8 defective		x

No.	Message	AB	FP
42	Warning! Shortage of pellets in storage area	x	
43	Fault in diverter for suction heads		x
44	Kommunikationsfehler Kaskade		x
46	The ash box is full and must be emptied	x	
47	Note: Maintenance - inspection	x	
48	Boiler cleaning recommended	x	
49	Boiler door or ash box is open	x	
50	The boiler door is open A boiler start is not possible	x	
51	Battery in operating element is dead		x
73	Fault in reference switch for suction heads		x

1 - Error in internal memory

An error has occurred in the memory of the boiler control. Check whether the customer/system-specific settings are present in the boiler control.

2 - Feeder sensor short circuit

The temperature sensor of the pellet auger has short-circuited and must be replaced.

3 - Ignition not possible! Check the container fill level sensor

Open the inspection cover on the pellet storage tank. Check whether there are any pellets in front of the sensor. If there are no pellets present, then the green LED should not light up. If it does, wipe the sensor. If there is no change, replace the sensor.

4 - Extraction room may be empty

Alarm is triggered when the runtime of the conveyor auger in the storage area is exceeded and when the level sensor in the pellet storage tank reports empty. Check the pellet level in the storage area.

5 - Flue gas temperature too low

The time limit for reaching the calculated flue gas required temperature has been exceeded. Clean the combustion grate, combustion chamber and flue pipe.

6 - Flue gas sensor disruption

The flue gas temperature sensor has a defect and must be replaced.

7 - Flue gas sensor shows wrong measured value

The flue gas temperature sensor has a defect and must be replaced.

8 - Feeder sensor disruption

The temperature sensor of the pellet auger has been disrupted and must be replaced.

9 - Flue gas sensor short circuit

The flue gas temperature sensor has a defect and must be replaced.

10 - Factory settings have been loaded

The customer-specific settings in the boiler control have been lost.

11 - Induced draught fan error

Message is triggered when the burner heats, but no speed is measured at the induced draught fan (IDF). Acknowledge the message, the IDF will be tested for one minute. After the test, an OK or Not OK message will be output.

12 - Induced draught fan running

Message during active IDF test run.

13 - The functionality of the induced draught fan is no longer intact

Cleaning of the exhaust pipe may be necessary. > 35

14 - Maximum suction time reached

Message is triggered when a specified time is exceeded during the suction filling of the pellet storage tank.

Cause / action

- The pellet storage area runs empty / > check pellet level in storage area
- Suction turbine, extraction motor or level sensor are defective / > acknowledge message and check (look/listen) whether the suction turbine or extraction motor starts up.
- The pellet hose is blocked / > visually check the pellet hose for blockage.
- Inspection cover on the pellet supply container leaking / > contact qualified personnel.

15 - Feed sensor shows wrong measured value

The temperature sensor of the pellet auger is defective and must be replaced.

16 - Lambda sensor defective

Message is triggered when the residual oxygen content in the induced draught fan is measured at over 15.5 % for a period of 1.5 hours.

17 - Boiler sensor defective

Message is triggered when a boiler temperature sensor short-circuits (display -30.0°C) or a disruption occurs (display 150.0°C). The burner stops, all pumps are switched off (to prevent a rise in the boiler temperature).

18 - Boiler temperature is too high

19 - Extraction auger is blocked

The thermal contact on the motor of the storage area auger has triggered. The boiler is still ready for operation.

Cause:

- The suction process took too long and overheated the motor.
- The motor was blocked by a blockage and overheated.
- Electrical contact fault in the motor feed line

Action:

- Switch the boiler off and allow it to cool down!
- Visually inspect the pellet hose for blockage, rectify as necessary.

20 - First ignition attempt was unsuccessful

The boiler remains in operation and starts a second ignition attempt. - If the second ignition attempt is also unsuccessful, message No. 40 is shown.

21 - Triac output feeder defective

22 - Triac output room extraction defective

23- DFSH module communication error

Communication between the boiler control and the electronic module of the diverter for suction heads (DFSH) is functioning, but...

Cause:

- - One of the two switches (proximity switch, reference switch) in the DFSH is defective, or there is a disruption, short-circuit.
- Cabling fault between DFSH (motor, switches) and electronic module.
- Input/output at the electronic module is defective.
- A fuse in the electronic module is defective.
- The motor of the DFSH is defective.

24 - Safety temperature limiter or safety chain has tripped

Due to a sudden reduction in the heat transfer, the boiler temperature can rise above 90°C. In this case, the integrated safety temperature limiter (STL) trips and initiates a rapid shut-down of the boiler.

Action:

- Wait until the boiler temperature has dropped below 70°C.
- Remove the sealing cap on the STL and depress the button until it stops.
- If the message appears again, notify qualified personnel.

25 - Power failure established

The message serves to inform the system operator that there was a power failure. The boiler is operationally ready again.

26 - Mains fuse defective

Mains fuse F3 on the electrical power element of the boiler is defective and must be replaced.

27 - Triac fuse defective

Triac fuse F6 on the electrical power element of the boiler is defective and must be replaced.

30 - Feeder is blocked

The pellet auger is blocked.

Possible cause:

- Too many pellets in the filling compartment of the boiler; often as a result of ignition faults due to improper combustion grate support, > 34

Action:

- Switch the boiler off and allow it to cool down. Check the combustion grate for soiling, heavy deposits.

31 - Heat exchangers are blocked

The power consumption of the heat exchanger cleaning motors is monitored by their boiler control. This message is triggered if the power consumption is too high. The boiler is still ready for operation.

32 - Heat exchangers are blocked

The power consumption of the heat exchanger cleaning motors is monitored by their boiler control. This message is triggered if the power consumption is too high. The boiler is switched off.

33 - Line disruption to the feeder motor

35 - CANbus disruption

Communication between the control panel and the boiler's electrical power element is disrupted.

Cause:

- Bus cable defective
- CANbus interface defective.

36 - Fuse at fresh water module defective

A fuse in the electronic module of the fresh water module is defective and must be replaced. (Message only possible with electronic module with RS485 bus system, not with CAN bus).

37 - Fuse at module defective

A fuse in the electronic module (solar module) is defective and must be replaced. (Message only possible with electronic module with RS485 bus system, not with CAN bus).

38 - Commissioning settings have been loaded

During commissioning of the heating system, the customer-specific settings were saved (by qualified personnel). The message is triggered when this saved status is loaded back into the control unit.

39 - Solar setting Max. tank temperature bottom can trip safety temperature limiter

The message is triggered when the parameter *Maximum tank temperature bottom* is set higher than 82°C in the solar settings of the control. CAUTION: The burner cannot start at the next request.

40 – Ignition not possible

This message appears after two unsuccessful ignition attempts.

Cause / action:

- Pellet storage tank is empty / > check whether pellets are being conveyed.
- The combustion chamber or flue gas pipe to the chimney are full of ash / > check
- The combustion chamber door is not closed properly / > check
- The combustion grate is covered with ash and should be cleaned / > check
- The combustion chamber is worn, pellets are falling through / > visual inspection inside the combustion chamber / ash container.
- Defective ignition device / > qualified personnel.
- An auger is defective (pellet auger, tank auger, storage area auger) / > contact qualified personnel

41 - FUSE F1 or F8 defective

Fuses on the electrical power section of the boiler. Message is triggered when the 24 V DC supply is not available for the digital outputs; possible cause: Fuse F1 or F8 defective.

42 - Warning! Shortage of pellets in storage area

Message triggered, if at the automatic suction probe switching unit only two suction probes are marked as *full* (if a total of only two probes is present, then if only one probe is still marked as *full*).

43 - Suction probe switching unit error

Communication between the boiler control and the electronic module of the diverter for suction heads (DFSH) is functioning, but...

Cause:

- - One of the two switches (proximity switch, reference switch) in the DFSH is defective, or there is a disruption, short-circuit.
- Cabling fault between DFSH (motor, switches) and electronic module.
- Input/output at the electronic module is defective.
- A fuse in the electronic module is defective.
- The motor of the DFSH is defective.

44 - Communication error cascade

46 - The ash box is full and must be emptied

47 - Warning! Maintenance– inspection

48 - Boiler cleaning recommended

49 - Boiler door or ash box is open

Check the cladding door and the cover of the ash box for correct seal.

50 - The boiler door is open A burner start is not possible

Check the cladding door for correct seal.

51 - Battery in operating element is dead

A replaceable buffer battery (CR2032) ensures that data (time, settings) are retained when the supply voltage is switched off.

73- Error in reference switch for suction heads

During the zero point search of the diverted for suction heads, the reference switch was not actuated by the intended mechanism.

Cause:

- The reference switch in the DFSH is defective, or there is a disruption, short-circuit.
- Cabling fault between DFSH (reference switch) and electronic module.
- Inaccurate position of the reference switch.

18 Boiler maintenance agreement

In order to maximise the convenience in use and lifetime of your boiler, it is recommended that you take out a maintenance contract. Under the maintenance contract, we take care of your boiler – because just like your car, your boiler should be serviced annually. The maintenance packages only become payable after the annual service.

For questions concerning the maintenance contract, please contact the SOLARFOCUS *Service Hotline* >

3

Basic package

Runtime

The term of the Basic Package is unlimited. The Basic Package can be purchased at any time for one-off servicing work on commissioning by SOLARFOCUS plant customer service or by a certified specialist service partner. The confirmed commissioning format is a prerequisite.

Services performed

- Annual boiler inspection and inspection according to maintenance checklist. The travel costs and working time are included as part of the annual maintenance charge. Checking of control parameters and if necessary a free software update will be performed.
- In addition, another free service application, if required, is included in the basic package.
- The replacement work for spare parts and wearing parts are included as part of the annual or one-off service.
- Spare parts and wearing parts are charged in line with actual consumption.

Other

- If cleaning is required or desired, it is charged separately.
- The servicing of boiler cascade systems is charged separately.

The maintenance dates will be scheduled by headquarters. Unless cancelled by you, the basic package is automatically extended by one year and billed accordingly. We reserve the right to impose annual price adjustments and this should be taken into account. The prices quoted are without the statutory value-added tax.



Runtime

The Power Package has a 5-year term. After this time, it is converted to a Basic package.

The Power Package can only be obtained from the SOLARFOCUS factory customer service at commissioning or by a certified service partner up to 6 months afterwards. The confirmed commissioning form is a prerequisite.

Services performed

- Annual boiler inspection and inspection according to maintenance checklist. The travel costs and working time are included as part of the annual maintenance charge. Checking of control parameters and if necessary a free software update will be performed.
- In addition, another free service application, if required, is included in the package.
- The replacement work for spare parts and wearing parts are included as part of the annual or one-off service.
- 5 years full warranty on the seal of the water-carrying components in the boiler body. 10-year warranty on the stainless steel filling chamber with the thermiⁿator II.
- 5 years full warranty on electromechanical components for the automatic fuel feed to the boiler (pellets & wood chips), such as suction turbine, gearmotors.
- 5 years full warranty on all electrical components on the boiler, such as motors, sensors, control, touch control unit or ignition.
- 2 years warranty on wear parts. Wearing parts are charged from the 3rd year. Wear parts include seals, refractory lining (clay bricks) in the combustion and ash chamber, hoppers made from cast chrome steel and stainless steel, fire-contacting components of the heat exchanger and flying ash cleaning unit as well as motor condensers.

Other

- If cleaning is required or desired, it is charged separately.
- The servicing of boiler cascade systems is charged separately.

The maintenance dates will be scheduled by headquarters. Unless cancelled by you, the Power Package is automatically extended by one year and billed accordingly. We reserve the right to impose annual price adjustments and this should be taken into account. The prices quoted are without the statutory value-added tax.

Premium package



Runtime

The Premium Package has a 10-year term. After this time, it is converted to a Basic package. The premium package can only be obtained from the SOLARFOCUS factory customer service at commissioning or by a certified service partner up to 6 months afterwards. The commissioning form signed by the customer is a prerequisite. A copy of the commissioning form must be transferred to SOLARFOCUS within 10 days of commissioning. The warranty starts upon the date of commissioning. Annual maintenance on the system must be performed in accordance with the maintenance checklist, and by the SOLARFOCUS plant customer service or a specialist service partner. A copy of the maintenance checklist, signed by the customer, must be transferred to SOLARFOCUS within 10 days of the maintenance.

Services performed

- Annual boiler inspection and inspection according to maintenance checklist.
- The replacement work for spare parts and wearing parts are included as part of the annual or one-off service.
- 10 years full warranty on the seal of the water-carrying components in the boiler body.
- 5 years full warranty on electromechanical components for the automatic fuel feed to the boiler (pellets & wood chips), such as suction turbine, gearmotors.
- 5 years full warranty on all electrical components on the boiler, such as motors, sensors, control, touch control unit or ignition.

- 5 years warranty on wear parts. Wearing parts are charged from the 6th year. Wear parts include seals, refractory lining (clay bricks) in the combustion and ash chamber, hoppers made from cast chrome steel and stainless steel, fire-contacting components of the heat exchanger and flying ash cleaning unit as well as motor condensers.

Other

- If cleaning is required or desired, it is charged separately.
- The servicing of boiler cascade systems is charged separately.

The maintenance dates will be scheduled by headquarters. The premium package will, unless you cancel it, be renewed automatically and billed annually. We reserve the right to impose annual price adjustments and this should be taken into account. The prices quoted are without the statutory value-added tax.

Applicable for all packages: The maintenance dates will be scheduled by the SOLARFOCUS company. Unless cancelled by you, maintenance packages are automatically extended by one year and billed accordingly. We reserve the right to impose annual price adjustments/increases and this should be taken into account.

Checklist (for all maintenance packages)

The annual boiler service includes the following:

- Visual assessment of the boiler, including wearing parts.
- Inspection and function check of all electrical and mechanical components, including automatic fuel feed to the boiler (pellets & wood chips)
- Visual inspection of the hydraulic safety fittings and the seal on the flue gas side; (however, correction of faulty seals is not included).
- Functional test of all connected measurement and control devices on the boiler.
- Functional test of the electrical safety devices.
- Test operation of the system and flue gas measurement (does not replace any local legal requirements for measurement).

19 ErP product data sheet

According to Regulation (EU) 2015/1187 and 2015/1189

Manufacturer	SOLARFOCUS GmbH., Werkstraße 1, 4451 St.Ulrich/Steyr			
Model designation	pellet^{top} 35	pellet^{top} 45	pellet^{top} 49	pellet^{top} 70
Energy efficiency class	A+	A+	A+	A+
Nominal heat output P_r kW	35	44.9	49	70
Energy Efficiency Index EEI %	121	122	122	122
Space heating annual usage η_s %	82	83	83	83
Special precautions to be taken for assembly, installation and main- tenance	The enclosed technical data sheets, assembly instructions and warranty passes must be observed before assembly, installation or maintenance. The relevant, country-specific standards and guidelines must be observed for the installation and operation of the solid fuel boiler.			

Innovative products to spare the environment
and your wallet!



Quality made in Austria

Biomass heating - Solar systems - Heat pumps - Fresh water equipment

Tested state-of-the-art technology – EN ISO 9001 certified



Austria

SOLARFOCUS GmbH, Werkstraße 1, A-4451 St. Ulrich/Steier

e-mail: office@solarfocus.at

Tel.: +43 (0) 7252 / 50 002 - 0

web: www.solarfocus.at

Fax: +43 (0) 7252 / 50 002 - 10